

# SaniForce<sup>®</sup> Heater

3A8940A

EN

**For heating fluids in ultra-high purity (sanitary) environments. Not approved for use in explosive atmospheres or hazardous (classified) locations. For professional use only.**

*60 psi (0.41 MPa, 4.1 bar) Maximum Working Pressure  
203°F (95°C) Maximum Operating Temperature*



## **Important Safety Instructions**

Read all warnings and instructions in this manual before using the equipment. Save these instructions.

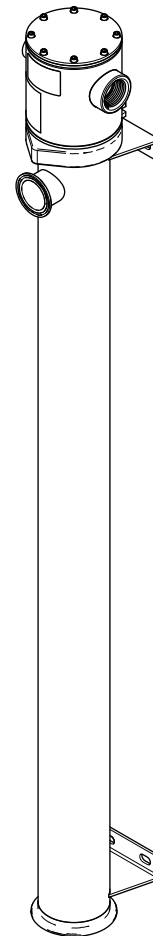

ti38871a

# Contents



<b>Models and Approvals</b> . . . . .	<b>3</b>	<b>Repair</b> . . . . .	<b>19</b>
<b>Warnings</b> . . . . .	<b>4</b>	Prepare Equipment for Repair . . . . .	19
<b>Description</b> . . . . .	<b>7</b>	Replace Heating Element . . . . .	19
<b>General Information</b> . . . . .	<b>7</b>	<b>Parts</b> . . . . .	<b>20</b>
<b>Typical Installation</b> . . . . .	<b>7</b>	<b>Kits and Accessories</b> . . . . .	<b>21</b>
<b>Installation</b> . . . . .	<b>8</b>	Part Kits . . . . .	21
Mount the Equipment . . . . .	8	Accessory Kits . . . . .	21
Grounding . . . . .	9	<b>Torque Instructions</b> . . . . .	<b>22</b>
Connect Supply Wiring . . . . .	10	<b>Torque Sequence</b> . . . . .	<b>22</b>
Before First Use . . . . .	11	<b>Electrical Schematics</b> . . . . .	<b>23</b>
<b>Operation</b> . . . . .	<b>12</b>	Wiring Diagram . . . . .	23
Pressure Relief Procedure . . . . .	12	Wiring for 208 V and 240 V Models . . . . .	24
Before Each Use . . . . .	12	Wiring for 400 V Models . . . . .	25
Start and Adjust the Equipment . . . . .	13	Wiring for 480 V Models . . . . .	26
Shutdown . . . . .	13	<b>Performance Charts</b> . . . . .	<b>27</b>
<b>Maintenance</b> . . . . .	<b>14</b>	Performance Charts for 12 kW Models . . . . .	27
Establish a Preventive Maintenance Schedule . . . . .	14	Performance Charts for 18 kW Models . . . . .	27
Flush the Equipment . . . . .	14	Performance Charts for 24 kW Models . . . . .	28
Store the Equipment . . . . .	14	<b>Dimensions</b> . . . . .	<b>29</b>
Routine Cleaning of Fluid Contact Section . . . . .	15	<b>Technical Specifications</b> . . . . .	<b>30</b>
<b>Recycling and Disposal</b> . . . . .	<b>15</b>	<b>California Proposition 65</b> . . . . .	<b>30</b>
End of Product Life . . . . .	15	<b>Graco Standard Warranty</b> . . . . .	<b>32</b>
<b>Troubleshooting</b> . . . . .	<b>16</b>		

# Models and Approvals

Record the model part number found on your equipment identification plate (ID) to assist you when ordering replacement parts:

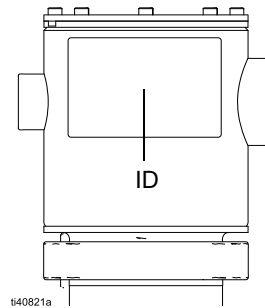

---









Part	Description	Approvals
26B065	24 kW, 208 V heater	<div style="text-align: center;">        </div> <p data-bbox="743 1008 1485 1071">Heating elements in all models are UL Recognized to UL 1030 and CSA C22.2 No. 72.</p>
26B756	24 kW, 240 V heater	
26B757	24 kW, 400 V heater	
26B758	24 kW, 480 V heater	
26B759	18 kW, 208 V heater	
26B760	18 kW, 240 V heater	
26B761	18 kW, 400 V heater	
26B762	18 kW, 480 V heater	
26B763	12 kW, 208 V heater	
26B764	12 kW, 240 V heater	
26B765	12 kW, 400 V heater	
26B766	12 kW, 480 V heater	

# Warnings

The following warnings are for the setup, use, grounding, maintenance, and repair of this equipment. The exclamation point symbol alerts you to a general warning and the hazard symbols refer to procedure-specific risks. When these symbols appear in the body of this manual or on warning labels, refer back to these Warnings. Product-specific hazard symbols and warnings not covered in this section may appear throughout the body of this manual where applicable.

 <b>DANGER</b>	
	<p><b>SEVERE ELECTRIC SHOCK HAZARD</b></p> <p>This equipment can be powered by more than 240 V. Contact with this voltage will cause death or serious injury.</p> <ul style="list-style-type: none"> <li>• Turn off and disconnect power at main switch before disconnecting any cables and before servicing equipment.</li> <li>• This equipment must be grounded. Connect only to grounded power source.</li> <li>• All electrical wiring must be done by a qualified electrician and comply with all local codes and regulations.</li> <li>• Do not expose to rain. Store indoors.</li> </ul>

 <b>WARNING</b>	
	<p><b>BURN HAZARD</b></p> <p>Equipment surfaces and fluid that is heated can become very hot during operation. To avoid severe burns:</p> <ul style="list-style-type: none"> <li>• Do not touch hot fluid or equipment.</li> </ul>
   	<p><b>FIRE AND EXPLOSION HAZARD</b></p> <p>Flammable fumes, such as solvent and paint fumes, in <b>work area</b> can ignite or explode. Paint or solvent flowing through the equipment can cause static sparking. To help prevent fire and explosion:</p> <ul style="list-style-type: none"> <li>• Use equipment only in well-ventilated area.</li> <li>• Eliminate all ignition sources; such as pilot lights, cigarettes, portable electric lamps, and plastic drop cloths (potential static sparking).</li> <li>• Ground all equipment in the work area. See <b>Grounding</b> instructions.</li> <li>• Never spray or flush solvent at high pressure.</li> <li>• Keep work area free of debris, including solvent, rags and gasoline.</li> <li>• Do not plug or unplug power cords, or turn power or light switches on or off when flammable fumes are present.</li> <li>• Use only grounded lines.</li> <li>• Hold gun firmly to side of grounded pail when triggering into pail. Do not use pail liners unless they are anti-static or conductive.</li> <li>• <b>Stop operation immediately</b> if static sparking occurs or you feel a shock. Do not use equipment until you identify and correct the problem.</li> <li>• Keep a working fire extinguisher in the work area.</li> </ul>

# ⚠️ WARNING



**EQUIPMENT MISUSE HAZARD**

Misuse can cause death or serious injury.



- Do not operate the unit when fatigued or under the influence of drugs or alcohol.
- Do not exceed the maximum working pressure or temperature rating of the lowest rated system component. See **Technical Specifications** in all equipment manuals.
- Use fluids and solvents that are compatible with equipment wetted parts. See **Technical Specifications** in all equipment manuals. Read fluid and solvent manufacturer’s warnings. For complete information about your material, request Safety Data Sheets (SDSs) from distributor or retailer.
- Do not leave the work area while equipment is energized or under pressure.
- Turn off all equipment and follow the **Pressure Relief Procedure** when equipment is not in use.
- Check equipment daily. Repair or replace worn or damaged parts immediately with genuine manufacturer’s replacement parts only.
- Do not alter or modify equipment. Alterations or modifications may void agency approvals and create safety hazards.
- Make sure all equipment is rated and approved for the environment in which you are using it.
- Use equipment only for its intended purpose. Call your distributor for information.
- Route lines and cables away from traffic areas, sharp edges, moving parts, and hot surfaces.
- Do not kink or over bend lines or use lines to pull equipment.
- Keep children and animals away from work area.
- Comply with all applicable safety regulations.



**THERMAL EXPANSION HAZARD**

Fluids subjected to heat in confined spaces, including lines, can create a rapid rise in pressure due to the thermal expansion. Over-pressurization can result in equipment rupture and serious injury.



- Open a valve to relieve the fluid expansion during heating.
- Replace lines proactively at regular intervals based on your operating conditions.

# **WARNING**



## **PRESSURIZED EQUIPMENT HAZARD**

Fluid from the equipment, leaks, or ruptured components can splash in the eyes or on skin and cause serious injury.



- Follow the **Pressure Relief Procedure** when you stop spraying/dispensing and before cleaning, checking, or servicing equipment.
- Tighten all fluid connections before operating the equipment.
- Check hoses, tubes, and couplings daily. Replace worn or damaged parts immediately.



## **PERSONAL PROTECTIVE EQUIPMENT**

Wear appropriate protective equipment when in the work area to help prevent serious injury, including eye injury, hearing loss, inhalation of toxic fumes, and burns. Protective equipment includes but is not limited to:

- Protective eyewear, and hearing protection.
- Respirators, protective clothing, and gloves as recommended by the fluid and solvent manufacturer.

## Description

The SaniForce Heater is an electric heating system to heat fluids in ultra-high purity (sanitary) environments. This heating system may be used with aggressive fluids, such as deionized water or acids, while maintaining the purity of those process fluids.

## General Information

- Typical installations are shown in FIG. 1 and FIG. 2. The figures are only guides for selecting and installing system components. Contact your Graco distributor for assistance in planning a system to suit your needs.
- Always use genuine Graco parts and accessories.
- Reference numbers and letters in parentheses refer to the callouts in the figures.

## Typical Installation

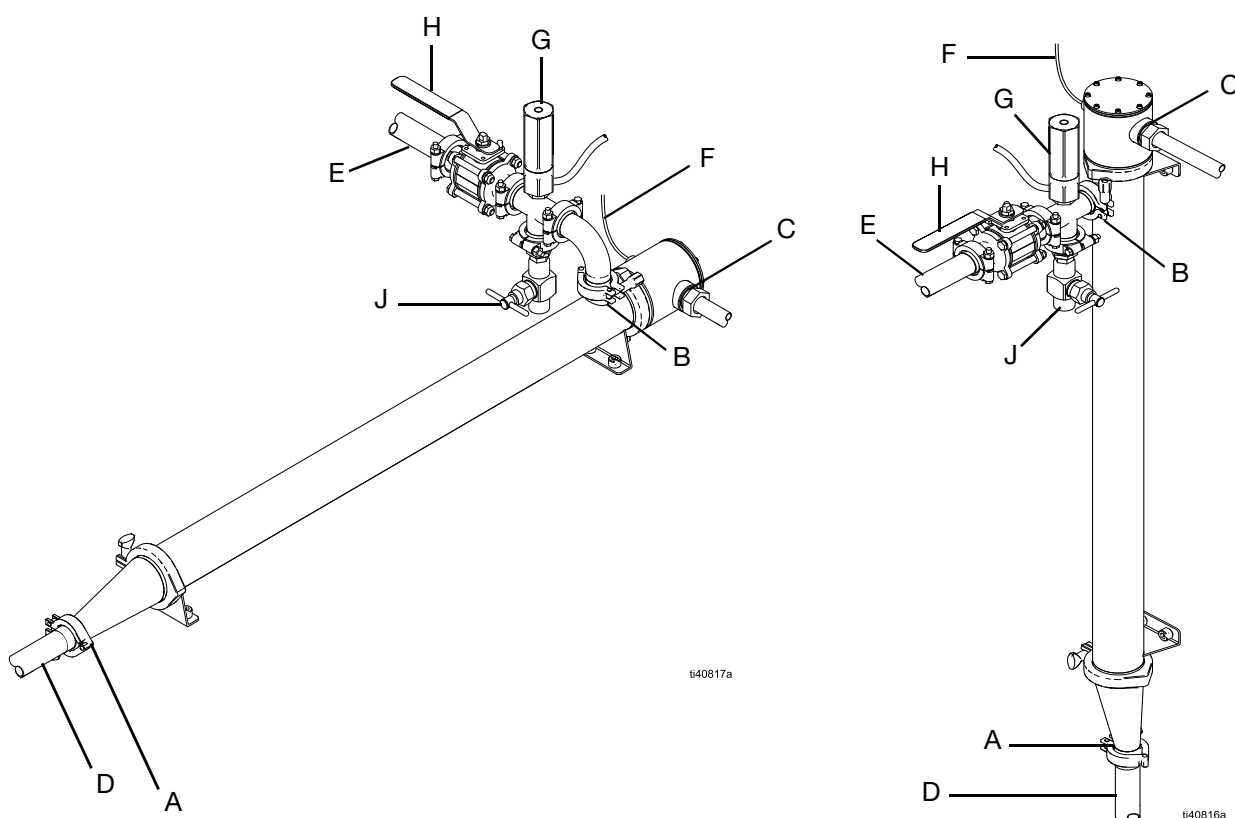

**FIG. 1: Horizontally Mounted Typical Installation**

### Key:

- A** Fluid inlet port
- B** Fluid outlet port
- C** Electrical wiring port
- D** Flexible, conductive fluid inlet line
- E** Flexible, conductive fluid outlet line

**FIG. 2: Vertically Mounted Typical Installation**

- F\*** Thermocouple wire
- G** Pressure relief valve (required, not supplied)
- H** Fluid shutoff valve (required, not supplied)
- J** Fluid drain valve (required, not supplied)

*\*Connect to a temperature controller (not shown; required, not supplied).*

# Installation

## Mount the Equipment



To prevent fire and explosion, locate equipment away from all flammable and combustible materials.

To avoid burns, mount in a location where operators will not come in contact with hot metal surfaces of the equipment. Insulate and label lines and components exiting equipment that may become hot.

The equipment may be mounted vertically or horizontally. See FIG. 1 and FIG. 2.

Follow the **Pressure Relief Procedure**, page 12, before moving the equipment.

1. Ensure that the mounting surface is level and can support the weight of the equipment, fluid, lines, and accessories, as well as the stress caused during operation.
2. For all mountings, be sure the equipment is firmly secured with fasteners through the mounting feet to the mounting surface. See **Dimensions**, page 29, and FIG. 3.

**NOTE:** For ease of operation and service, mount the equipment so the electrical wiring port (C), fluid inlet port (A), and fluid outlet port (B) are easily accessible.

**NOTE:** To ensure fluid contact with heating elements, mount the equipment so that the fluid outlet port (B) is above the fluid inlet port (A). See **Typical Installation**, page 7.

**NOTE:** A pressure relief valve is required. Install the pressure relief valve (G) downstream from the equipment, as close to the outlet port (B) as possible. See FIG. 1 and FIG. 2.

**NOTICE**

To prevent equipment damage, use all fastener holes to firmly secure all feet to the mounting location.

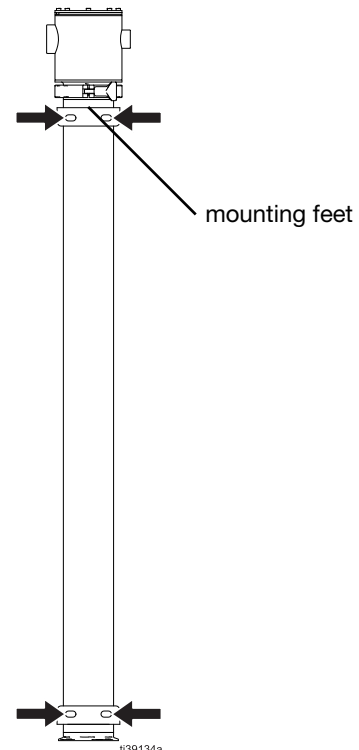

**FIG. 3: Mounting Holes**



## Grounding

<p>The equipment must be grounded to reduce the risk of static sparking and electric shock. Electric or static sparking can cause fumes to ignite or explode. Improper grounding can cause electric shock. Grounding provides an escape wire for the electric current.</p>			

**Ground the heater:** Ground the heater to a properly grounded power source. Connect the ground wire to the ground terminal. See FIG. 5.

1. Ensure that the electrical disconnect (AA) to the heater is shut off and locked.

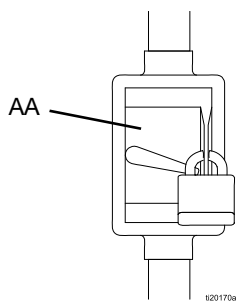

**FIG. 4: Electrical Disconnect**

2. Remove the fasteners (9), washers (8), cap (7), and o-ring (6) to access the electrical wiring compartment.
3. Insert the supply ground wire through the electrical wiring port (C).
4. Connect one end of the supply ground wire to the ground terminal (10a).
 

**NOTE:** The ground terminal (10a) is a 1/4-20 thread. Torque to 75 in-lb (8.5 N•m).
5. Connect the other end of the supply ground wire to a true earth ground.
6. Install the o-ring (6), cap (7), washers (8), and fasteners (9). Torque fasteners (9) to 20 in-lb (2.2 N•m). See **Torque Sequence**, page 22.

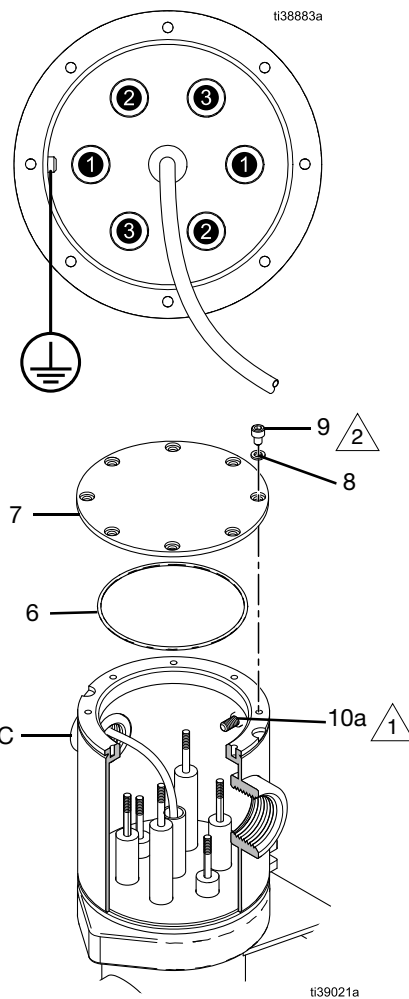

- Torque to 75 in-lb (8.5 N•m).
- Torque to 20 in-lb (2.2 N•m).



**FIG. 5: Ground Terminal**

**Ground the fluid lines:** Use only electrically conductive lines with a maximum of 500 ft. (150 m) combined line length to ensure grounding continuity. Check electrical resistance of lines. If total resistance to ground exceeds 25 megohms, replace line immediately.

**Ground the fluid supply and receiving containers:** Follow local codes and regulations.

**Ground solvent pails used when flushing:** Follow local codes and regulations. Use only conductive metal pails, placed on a grounded surface. Do not place the container on a nonconductive surface, such as paper or cardboard, which interrupts grounding continuity.

## Connect Supply Wiring

				
All electrical wiring must be done by a qualified electrician and comply with all local codes and regulations.				

Ensure the equipment is connected to a temperature controller that limits the operating temperature to 203°F (95°C) or less.

See **Technical Specifications**, page 30, for electrical requirements.

<b>NOTICE</b>
To prevent voltage fluctuations that may result in equipment damage, use the proper temperature controller, voltage, wiring, fusing, sensors, and sizing of electrical connections for your equipment.

1. Ensure that the electrical disconnect (AA) to the heater is shut off and locked.

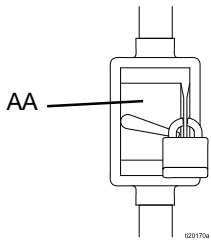

**FIG. 6: Electrical Disconnect**

2. Remove the fasteners (9), washers (8), cap (7), and o-ring (6) to access the electrical wiring compartment.
3. Insert electrical wires through the electrical wiring port (C).
4. Connect wires to terminals. See **Electrical Schematics**, starting on page 23.



**NOTE:** Conductors and terminals used for supply connection must be suitable for 221°F (105°C) or greater.

**NOTE:** Heater terminals are 1/4-20 thread. Torque to 75 in-lb (8.5 N•m).

<b>NOTICE</b>
To prevent equipment damage, do not torque terminal nuts more than 75 in-lb (8.5 N•m).

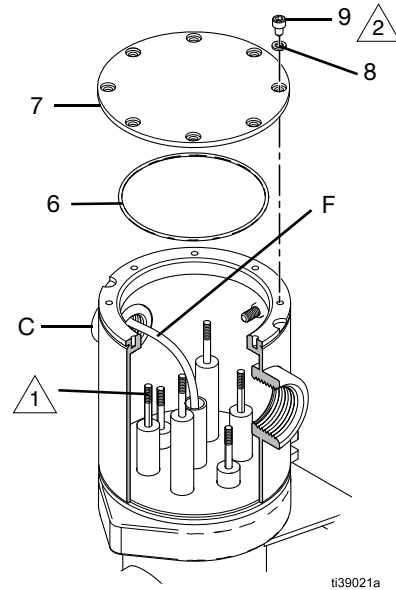
5. Install the o-ring (6), cap (7), washers (8), and fasteners (9). Torque fasteners (9) to 20in-lb (2.2 N•m). See **Torque Sequence**, page 22.



-  Torque terminal nuts to 75 in-lb (8.5 N•m).
-  Torque to 20 in-lb (2.2 N•m).

**FIG. 7**

## Connect Thermocouple

A Type J thermocouple is permanently installed in the system. Connect the thermocouple wire (F) to your temperature controller (required, not supplied).

<b>NOTICE</b>
Do not exceed the maximum operating temperature of 203°F (95°C). Operating the equipment outside of these conditions can result in premature heater failure, heater short, or potentially hazardous heater burnout.

Install a second temperature sensor (required, not supplied) as close to the fluid outlet port as possible to measure fluid outlet temperature.

## Connect Over-Current Protective Devices

Prior to powering on, install external over-current protective devices (required, not supplied) to the equipment. See **Technical Specifications**, page 30, for electrical requirements.

## Before First Use

### Tighten Fasteners

Before using the equipment for the first time, check and torque all fasteners. See **Torque Instructions**, page 22.

After the first day of operation, re-torque the fasteners.

**NOTE:** Be sure to use a compatible liquid thread sealant on all male threads. Securely tighten all fittings and plugs. Re-torque all fasteners before starting the equipment. See **Torque Instructions**, page 22.

#### **NOTICE**

To avoid equipment damage, do not over-torque the fasteners on the equipment.

### Tighten Connections

Check and tighten all fluid connections before operating the equipment. Replace worn or damaged parts as needed.

#### **NOTICE**

Firmly tighten all connections to avoid leaks and damage to equipment parts.

### Flush the Equipment

The equipment was tested with a glycerin and water solution. If glycerin or water could contaminate your fluid, flush the equipment with a compatible solvent before using the equipment. Follow **Flush the Equipment**, page 14.

# Operation

## NOTICE

Do not apply power to the equipment without a minimum flow of 0.5 gpm (1.89 lpm) and a minimum outlet pressure of 20 psi (1.38 bar, 0.14 MPa), and do not exceed the maximum operating temperature of 203°F (95°C). Operating the equipment outside of these conditions can result in premature heater failure, heater short, or heater burnout.

## Pressure Relief Procedure

For pressure relief procedures specific to your pump, see your pump manual.



Follow the Pressure Relief Procedure whenever you see this symbol.



This equipment stays pressurized until pressure is manually relieved. To help prevent serious injury from pressurized fluid, such as splashing fluid, follow the Pressure Relief Procedure when you stop dispensing and before cleaning, checking, or servicing the equipment.

1. Turn off and disconnect power to the heater.
2. Circulate fluid through the system to cool the heated fluid and heater.
3. Turn off the pump and disconnect power to the system.
4. Close your system fluid inlet valve.
5. Open outbound fluid dispense valve to relieve fluid pressure from the system.
6. Open the fluid drain valve (J).
7. Drain the fluid into a grounded waste container to relieve pressure.
8. Open any fluid drain valves in the system.
9. Leave the drain valve open until you are ready to pressurize the system.

## Before Each Use

### Tighten Fasteners

Check and tighten all fasteners before operating the equipment. Re-torque as needed. See **Torque Instructions**, page 22.

**NOTE:** Be sure to use a compatible liquid thread sealant on all male threads. Securely tighten all fittings and plugs. Re-torque all fasteners before starting the equipment. See **Torque Instructions**, page 22.

## NOTICE

To avoid equipment damage, do not over-torque the fasteners on the equipment.

### Tighten Connections

Check and tighten all fluid connections before operating the equipment. Replace worn or damaged parts as needed.

## NOTICE

Firmly tighten all connections to avoid leaks and damage to equipment parts.

### Flush the Equipment

Flush the equipment before each use. See **Flush the Equipment**, page 14.

## Start and Adjust the Equipment



Thermal expansion can cause over-pressurization, resulting in equipment rupture and serious injury from splashing fluids. Do not pressurize the system when preheating the equipment.

### NOTICE

Heated equipment must always contain fluid when the power is on. Never turn on heat zone switches while equipment is empty. Heating empty equipment may cause equipment damage.

See your separate temperature controller manual for directions on operating the system.

## Determine Heater Temperature

For maximum equipment life, use the lowest temperature setting needed.

### NOTICE

Operating the equipment at its highest setting, 203°F (95°C), for long periods of time decreases the equipment life. Temperatures higher than necessary may also cause the fluid to dry out, resulting in a poor finish and clogged equipment.

## Shutdown

1. Perform **Flush the Equipment**, page 14.
2. Perform **Pressure Relief Procedure**, page 12.
3. Verify that the equipment is turned off and power to the system is disconnected.
4. Allow equipment to cool.

# Maintenance

## Establish a Preventive Maintenance Schedule

Establish a preventive maintenance schedule based on the equipment service history.

### Inspect the Equipment

Regularly inspect the equipment for worn or damaged parts. Replace worn or damaged parts as needed.

### Torque Fasteners

Regularly check and torque all fasteners. See **Torque Instructions**, page 22.

**NOTE:** Be sure to use a compatible liquid thread sealant on all male threads. Securely tighten all fittings and plugs. Re-torque all fasteners before starting the equipment. See **Torque Instructions**, page 22.

<b>NOTICE</b>
To avoid equipment damage, do not over-torque the fasteners on the equipment.

### Tighten Connections

Check and tighten all fluid connections before operating the equipment. Replace worn or damaged parts as needed.

<b>NOTICE</b>
Firmly tighten all connections to avoid leaks and damage to equipment parts.

## Flush the Equipment

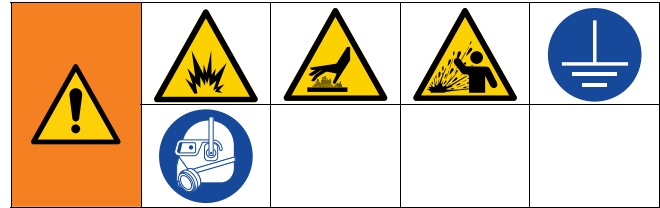

To avoid fire and explosion, always ground equipment and waste container. To avoid static sparking and injury from splashing, always flush at the lowest possible pressure.

Hot solvent may ignite. To avoid fire and explosion:

- Flush equipment only in a well-ventilated area
- Ensure main power is off and equipment is cool before flushing
- Do not turn on equipment until fluid lines are clear of solvent

- Before flushing, ensure the equipment is off and power to the system is disconnected.
  - Flush before fluid can dry in the equipment, at the end of the day, before storing, and before repairing equipment.
  - Flush at the lowest pressure possible. Check connectors for leaks and tighten as necessary.
  - Flush with cool water or a fluid that is compatible with the fluid being dispensed and the equipment wetted parts.
1. Perform **Pressure Relief Procedure**, page 12.
  2. Set your pump to the lowest possible fluid pressure, and start the pump.
  3. Run the pump until clean solvent dispenses.

## Store the Equipment

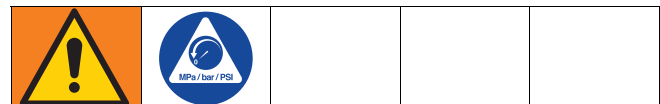

Always relieve the pressure and flush the equipment before storing the equipment for any length of time.

1. Perform **Flush the Equipment**, page 14.
2. Perform **Pressure Relief Procedure**, page 12.

## Routine Cleaning of Fluid Contact Section



**NOTE:** The system should be cleaned in accordance with applicable codes and local regulations for your compatible solvent.

1. Perform **Flush the Equipment**, page 14.
2. Perform the **Pressure Relief Procedure**, page 12.
3. Disassemble equipment as needed.
4. Using a brush, wash all product contact pump parts with a compatible solvent at the manufacturer's recommended temperature and concentration. Follow local codes and regulations.
5. Rinse these parts again with water and allow parts to completely dry.
6. Inspect all parts for wear or damage, and re-clean any soiled parts. Replace parts as needed.
7. Reassemble parts as needed.
8. Circulate the compatible solvent through the system prior to use. Cycle the pump as the compatible solvent is circulated.

## Recycling and Disposal

### End of Product Life



At the end of the product's useful life, dismantle and recycle it in a responsible manner.

- Perform the **Pressure Relief Procedure**, page 12.
- Drain and dispose of fluids according to applicable regulations. Refer to the material manufacturer's Safety Data Sheet.
- Remove electronic components. Recycle according to applicable regulations.
- Do not dispose of electronic components with household or commercial waste.



- Deliver remaining product to a recycling facility.

# Troubleshooting

			
<p><b>DANGER</b>  <b>SEVERE ELECTRIC SHOCK HAZARD</b></p> <p>This equipment can be powered by more than 240 V. Contact with this voltage will cause death or serious injury.</p> <p>When accessing the electrical enclosure while power is present:</p> <ul style="list-style-type: none"> <li>• Do not make contact with components of wires unless instructed to do so.</li> <li>• Wear appropriate personal protective equipment.</li> </ul>			



1. Perform the **Pressure Relief Procedure**, page 12, before checking or repairing the equipment.
2. Check all possible problems and causes before disassembling the equipment.

Problem	Cause	Solution
Equipment not running	Poor supply power.	Check connections. Determine and fix source of the problem with supply power.
	System circuit breaker is off or tripped	Reset the circuit breaker.
	Electrical connections are loose or damaged	Check for continuity between the electrical terminals inside the equipment and power source. Ensure terminal connections are secure. Replace damaged parts as needed.
	Equipment electrical elements are damaged	Check electrical continuity. Replace heater elements as needed.
Fluid leaking	Loose fasteners or fluid connection	Check and tighten fasteners and fluid connections. Replace as needed.
	Worn seals	Replace seals.
Fluid delivery is slow or low	Pressure setting is too low	Increase pressure.
	Large pressure drop in fluid line	Use larger diameter or shorter line.
	Low or empty fluid supply	Refill the fluid supply and reprime the pump.
	Obstructed fluid line	Clear obstruction.
Air bubbles in fluid	Supply line is loose	Tighten.









Problem	Cause	Solution
No heat	Heat zone turned off	Turn on the heat zone switch.
	System circuit breaker is off or tripped	Reset the circuit breaker.
	Thermocouple is not functioning	Verify that the thermocouple wires are properly connected to the temperature controller. Ensure wires are not pinched.
	The temperature controller is not actively trying to heat.	Verify the temperature setpoint is correct. Adjust the temperature setpoint as needed. Replace temperature controller as needed.
	Electrical connections are loose or damaged	Check for continuity between the electrical terminals inside the equipment and power source. Ensure terminal connections are secure. Replace damaged parts as needed.
	Equipment electrical elements are damaged	Check electrical continuity. Replace heater elements as needed.
	Failed temperature controller	Check for continuity between controller and equipment. Replace controller as needed.
	The wrong temperature controller is installed	Verify that the correct temperature controller for your equipment is installed. See <b>Technical Specifications</b> , page 30, for electrical requirements.
Equipment overheating	Fluid not covering interior heating elements, interior heating elements exposed to air	Ensure equipment contains fluid before turning on heat zone switches.
	Flow and outlet pressure too low	Ensure the system is operating with a minimum flow of 0.5 gpm (1.89 lpm) and a minimum outlet pressure of 20 psi (1.38 bar, 0.14 MPa).
	Equipment set to exceed maximum operating temperature	Ensure the set operating temperature does not exceed the maximum temperature of 203°F (95°C). See <b>Technical Specifications</b> , page 30.

Problem	Cause	Solution
Temperature variation	Low input voltage or voltage fluctuation	The maximum amount of heat depends on the input voltage. Verify that the correct temperature controller, voltage, wiring, fusing, sensors, and sizing of electrical connections are used for your equipment. See <b>Technical Specifications</b> , page 30 for electrical requirements.
	Electrical connections are loose or damaged	Check for continuity between the electrical terminals inside the equipment and power source. Ensure terminal connections are secure. Replace damaged parts as needed.
	Equipment electrical elements are damaged	Check electrical continuity. Replace heater elements as needed.
	The wrong temperature controller is installed	Verify that the correct temperature controller for your equipment is installed. See <b>Technical Specifications</b> , page 30, for electrical requirements.
	Material temperature at the pump inlet is too low	Increase the temperature of the material before use.
	Material cooling in fluid lines	Use a fluid line that maintains the temperature of the fluid while the fluid travels through the line.

# Repair

## Prepare Equipment for Repair



Servicing this equipment requires access to parts which may cause electric shock or other serious injury if work is not properly performed.

- Do not service this equipment unless you are trained and qualified.
- To reduce risk of injury, follow the **Pressure Relief Procedure** before checking, servicing, or repairing the equipment.

Always complete the following procedure before performing any service or repair to the equipment.

1. Perform **Flush the Equipment**, page 14.
2. Perform the **Pressure Relief Procedure**, page 12.
3. Verify that the equipment is turned off and power to the system is disconnected before performing any service or repair procedure.
4. Allow equipment to cool.

## Replace Heating Element

				
---	---	--	--	--

**DANGER**  
**SEVERE ELECTRIC SHOCK HAZARD**

This equipment can be powered by more than 240 V. Contact with this voltage will cause death or serious injury.

When accessing the electrical enclosure while power is present:

- Do not make contact with components of wires unless instructed to do so.
- Wear appropriate personal protective equipment.

### Disassemble Heating Elements

1. Perform **Prepare Equipment for Repair**, page 19.
2. Disconnect electrical wires from external connections.
3. Disconnect all fluid lines from the equipment.
4. Remove clamp (5).
5. Remove heating element assembly (1).
6. Clean and inspect all parts for wear or damage. Replace as needed.

### Reassemble Heating Elements

1. Install heating element assembly (1).
2. Install clamp (5).
3. Connect electrical wires. See **Electrical Schematics**, page 23.
4. Connect fluid lines to the equipment.

# Parts

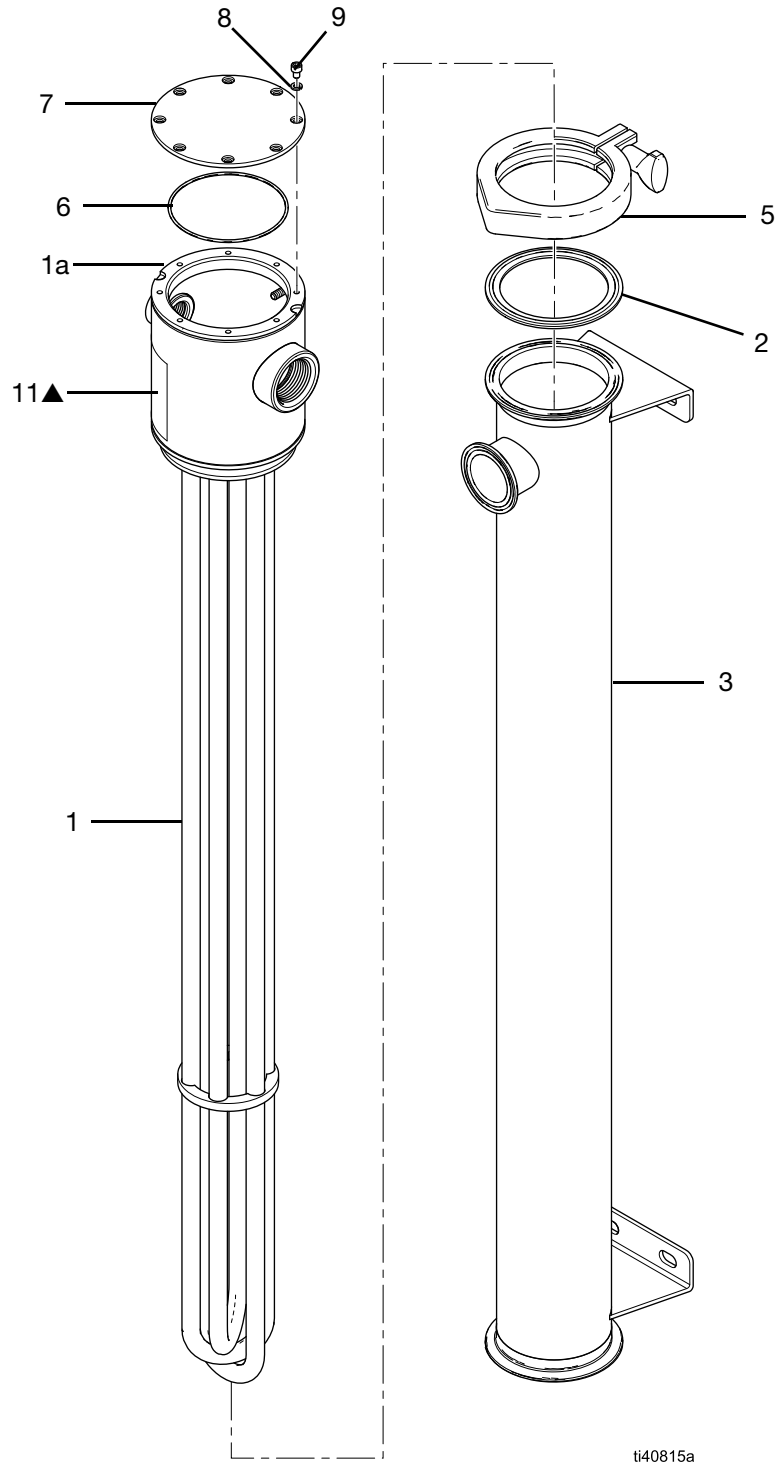

## Parts

Ref.	Part	Description	Qty.
1		HEATER, weldment, heating elements	1
	19B301	for 24 kW, 208 V heater	
	19C464	for 24 kW, 240 V heater	
	19C465	for 24 kW, 400 V heater	
	19C466	for 24 kW, 480 V heater	
	19C467	for 18 kW, 208 V heater	
	19C468	for 18 kW, 240 V heater	
	19C469	for 18 kW, 400 V heater	
	19C470	for 18 kW, 480 V heater	
	19C471	for 12 kW, 208 V heater	
	19C472	for 12 kW, 240 V heater	
	19C473	for 12 kW, 400 V heater	
19C474	for 12 kW, 480 V heater		
1a	---	BODY, tube, J-box; <i>included with Ref. 1</i>	1
2	15H459	GASKET, sanitary, 3 in. Tri-Clamp, EPDM	1
3		TUBE, vessel, weldment	1
	19B291	for 24 kW heaters	
	19C254	for 18 kW heaters	
	19C525	for 12 kW heaters	
5	15D475	CLAMP, sanitary, 3 in.	1
6	120932	O-RING, FKM	1
7	19B299	CAP, top, J-box, heater	1
8	112917	WASHER, lock, spring	8
9	123909	FASTENER, cap, socket head, 8-32 x 1/4 in.	8
11▲	19F556	LABEL, danger, safety	1
	15K616	LABEL, safety	1

▲ Replacement safety labels, tags, and cards are available at no cost.

--- Not available separately.

## Kits and Accessories

Additional kits and accessories are available (purchase separately).

### Part Kits

#### Gasket Kits

Ref.	Part	Description	Kits Include
2	19B141	GASKET, sanitary, 3 in. Tri-Clamp, FKM	1 gasket
	19B149	GASKET, sanitary, 3 in. Tri-Clamp, EPDM/PTFE	
	17Z537	GASKET, sanitary, 3 in. Tri-Clamp, Nitrile	

### Accessory Kits

#### Inlet Port Kits

Part	Description	Kits Include
19B290	FITTING, eccentric reducer; sanitary, 1.5 in. and 3 in. Tri-Clamp ports	1 inlet fitting

#### Inlet Clamp Kits

Part	Description	Kits Include
15D475	CLAMP, sanitary, 3 in.	1 clamp

## Torque Instructions

To ensure proper sealing, torque fasteners using the following procedure.

1. Start all fasteners a few turns.
2. Follow the torque sequence to turn down each fastener until just under specified torque.
3. Follow the torque sequence to turn each fastener by 1/2 turn or less until at specified torque.

## Torque Sequence

Torque fasteners (9) on cap (7) to 20 in-lb (2.2 N•m).

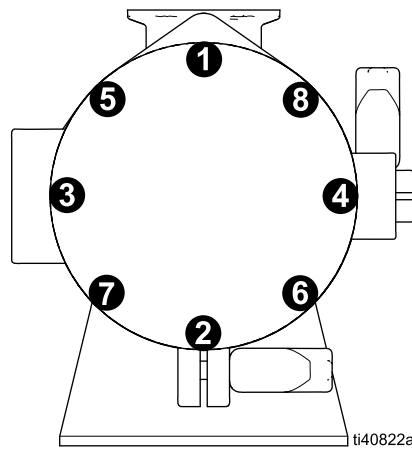

# Electrical Schematics

## Wiring Diagram

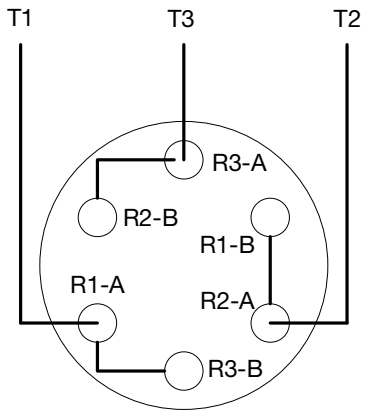

Phase T1: R1-A, R3-B

Phase T2: R2-A, R1-B

Phase T3: R3-A, R2-B

## Wiring for 208 V and 240 V Models

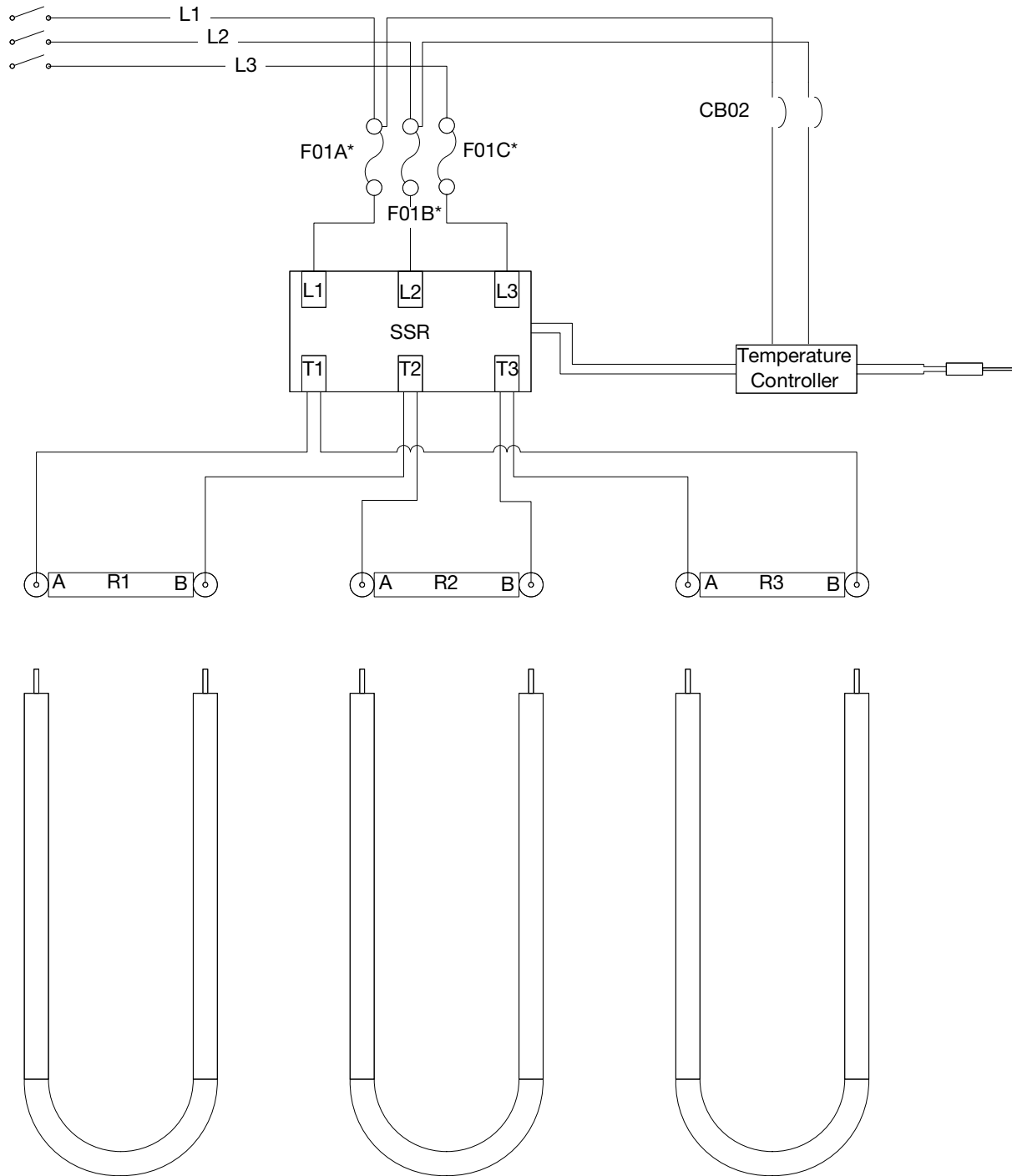

**\* Branch Circuit Fuse Requirements:**

	Power	Fuse
<b>208 V Models</b>	12 kW	50 A
	18 kW	70 A
	24 kW	90 A

**\* Branch Circuit Fuse Requirements:**

	Power	Fuse
<b>240 V Models</b>	12 kW	40 A
	18 kW	60 A
	24 kW	80 A



## Wiring for 400 V Models

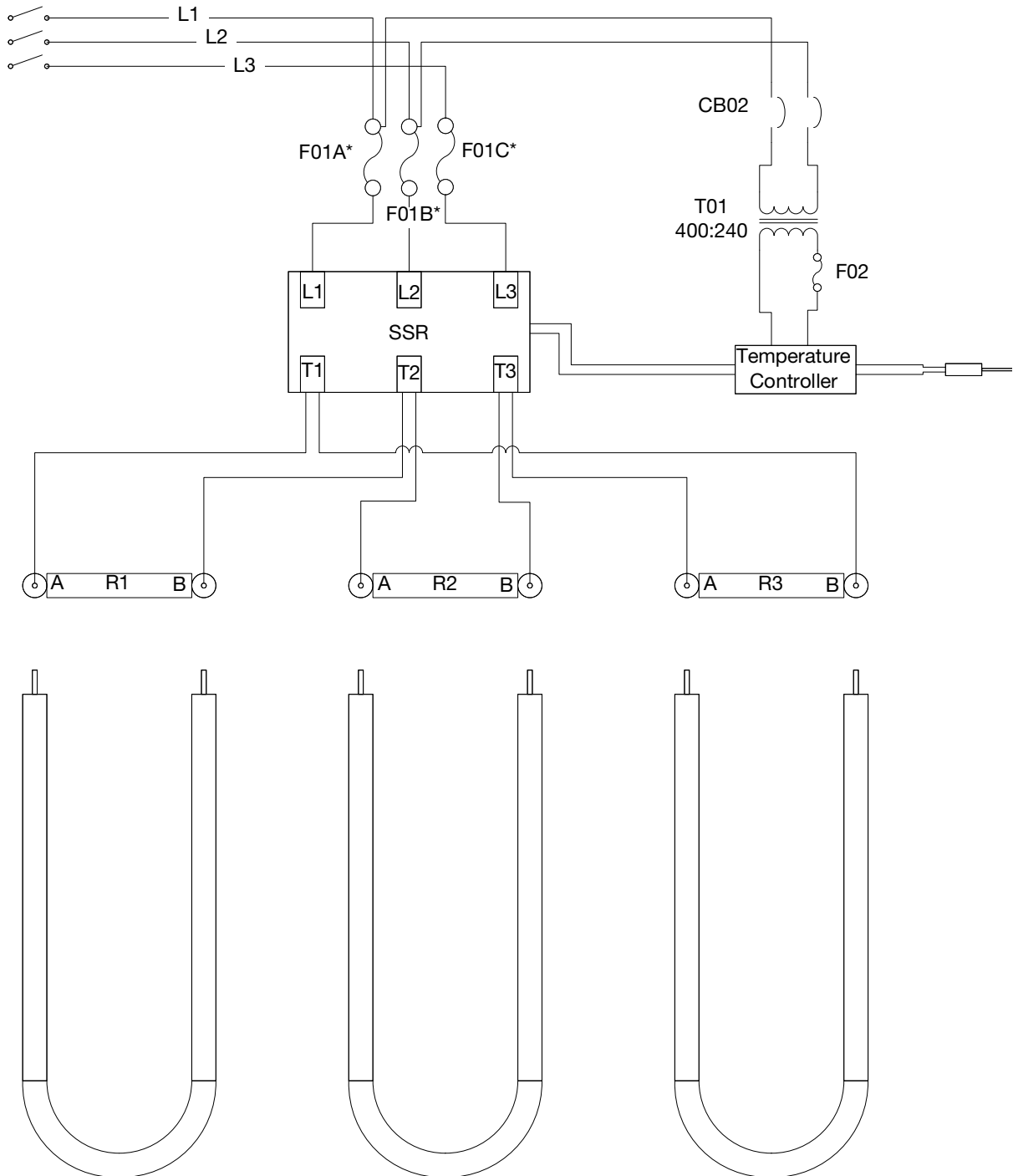

\* Branch Circuit Fuse Requirements:

	Power	Fuse
400 V Models	12 kW	25 A
	18 kW	35 A
	24 kW	50 A

## Wiring for 480 V Models

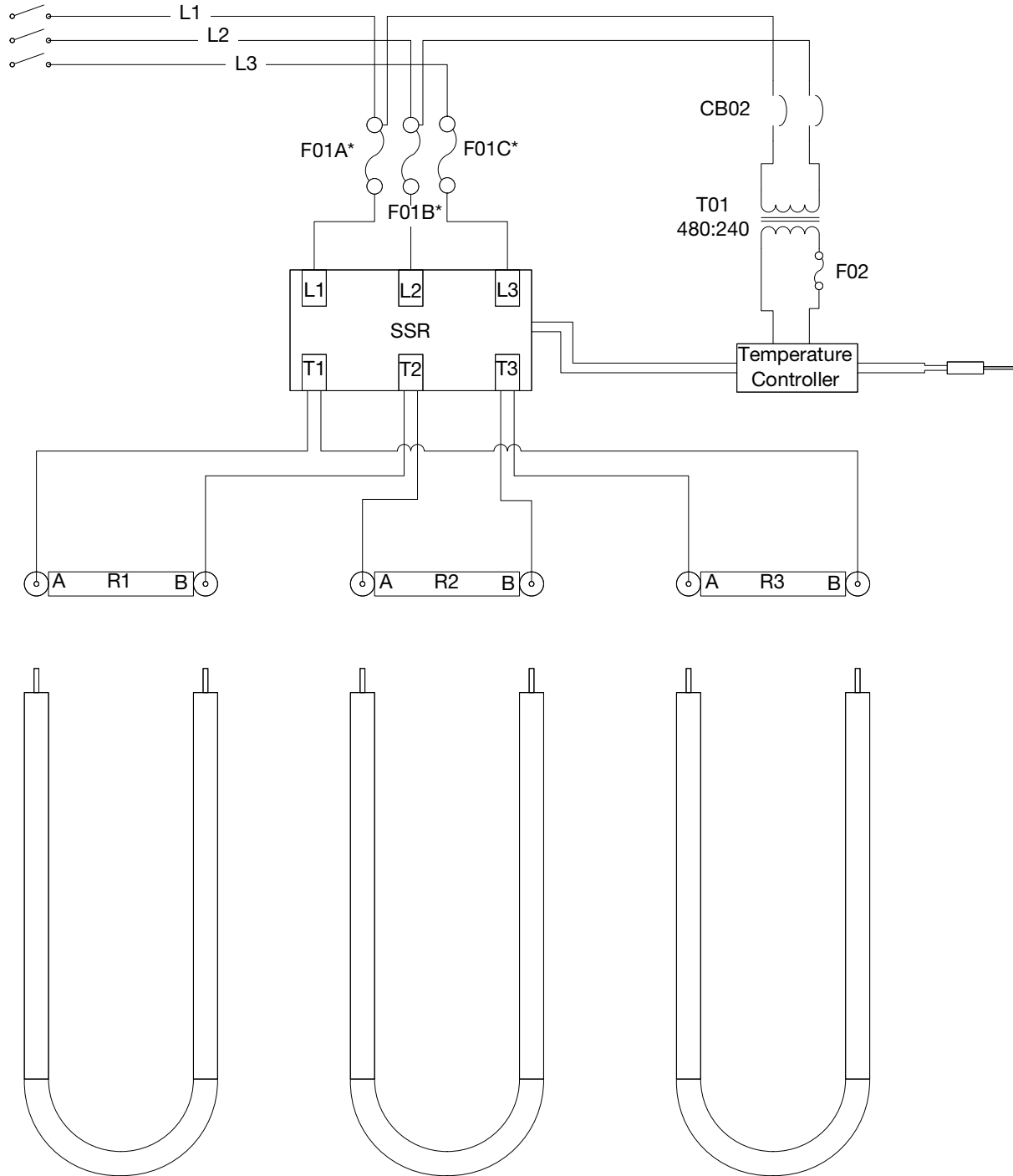

**\* Branch Circuit Fuse Requirements:**

	Power	Fuse
<b>480 V Models</b>	12 kW	20 A
	18 kW	30 A
	24 kW	40 A

# Performance Charts

## Performance Charts for 12 kW Models

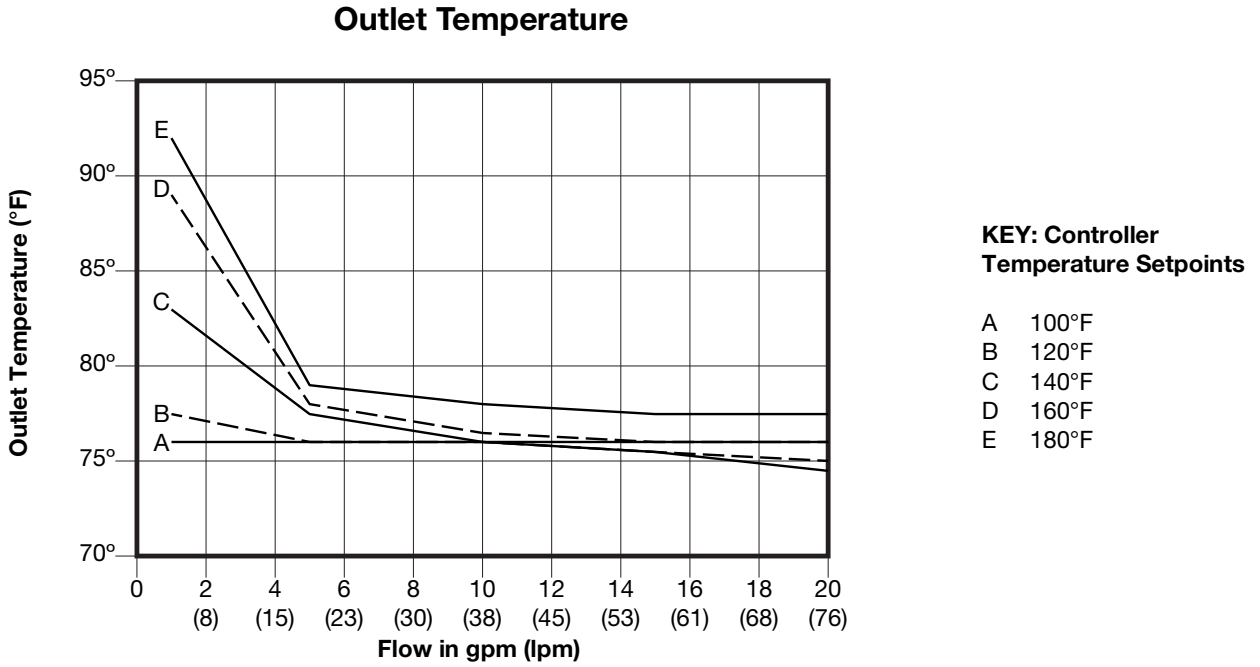

## Performance Charts for 18 kW Models

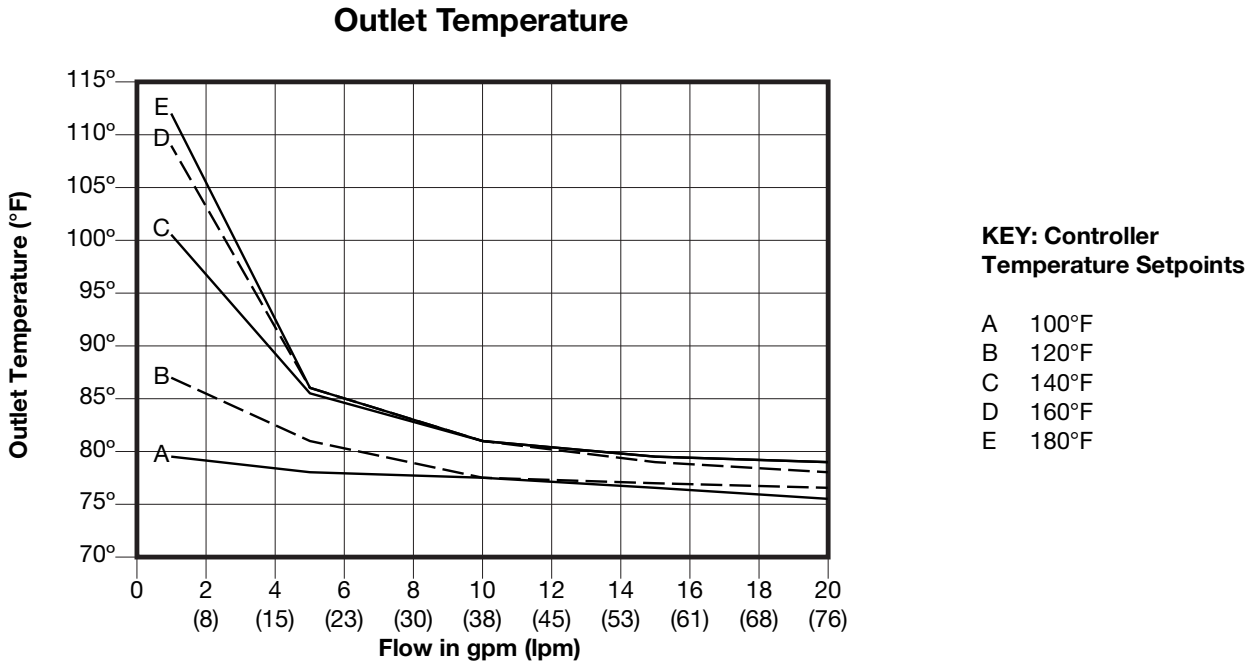

# Performance Charts for 24 kW Models

## Outlet Temperature

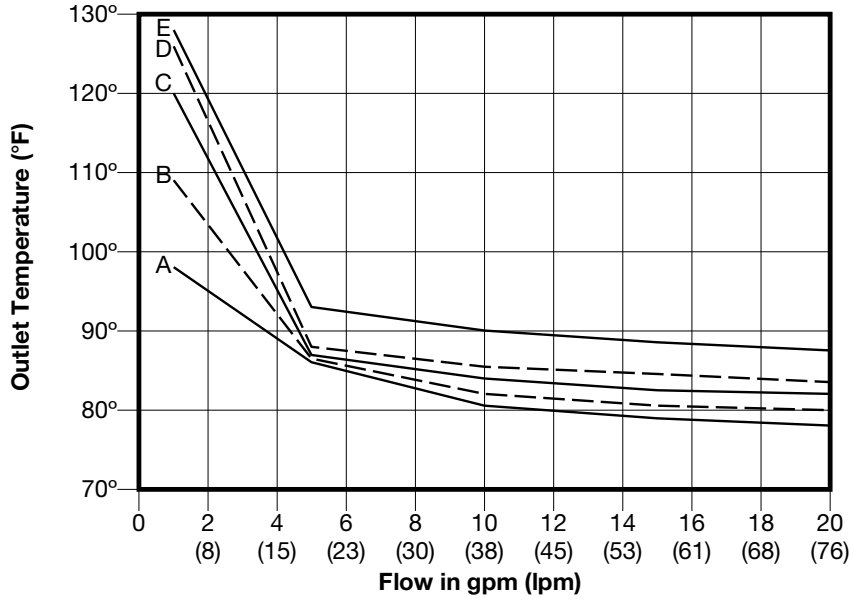

**KEY: Controller  
Temperature Setpoints**

- A 100°F
- B 120°F
- C 140°F
- D 160°F
- E 180°F

# Dimensions

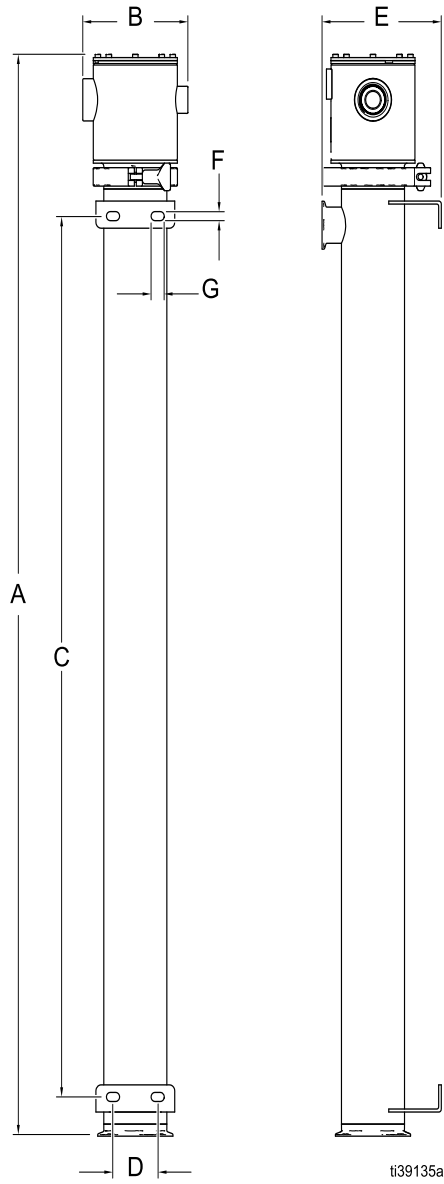

<b>Model</b>	<b>A</b> in. (cm)	<b>B</b> in. (cm)	<b>C</b> in. (cm)	<b>D</b> in. (cm)	<b>E</b> in. (cm)	<b>F</b> in. (cm)	<b>G</b> in. (cm)
24 kW models	44.7 (114)	4.0 (10.16)	36.5 (93)	2.13 (5.41)	6.6 (16.76)	0.375 (0.95)	0.625 (1.59)
18 kW models	33.7 (86)		27.5 (70)				
12 kW models	26.7 (68)		18.5 (47)				

# Technical Specifications

<b>SaniForce Heater</b>		
	<b>US</b>	<b>Metric</b>
Maximum fluid working pressure	60 psi	0.41 MPa, 4.1 bar
Environmental temperature range	Operating Storage	41° to 104°F
		5° to 40°C
		–40° to 140°F
		–40° to 60°C
Maximum fluid temperature	203°F	95°C
<b>Inlet/Outlet Sizes</b>		
Fluid inlet size	3 in. Tri-Clamp	
Fluid outlet size	1.5 in. Tri-Clamp	
<b>Materials of Construction</b>		
Housing (wetted parts)	316L Stainless Steel	
<b>Control Options</b>		
Temperature sensor	Type J thermocouple	
<b>Notes</b>		
All trademarks or registered trademarks are the property of their respective owners.		

<b>Electrical Ratings and Weight</b>						
<b>Model Part Number</b>	<b>Power (kW)</b>	<b>AC Voltage</b>	<b>Nominal Resistance, per element (Ohms)</b>	<b>Nominal Amperage, per element (Amps)</b>	<b>Nominal Amperage, total (Amps)</b>	<b>Weight (lb (kg))</b>
26B065	24	3-Phase, 208 V	5.4	38.5	66.7	23.0 (10.4)
26B756		3-Phase, 240 V	7.2	33.3	57.7	
26B757		3-Phase, 400 V	20.0	20.0	34.6	
26B758		3-Phase, 480 V	28.8	16.7	28.9	
26B759	18	3-Phase, 208 V	7.2	28.9	50.0	18.5 (8.4)
26B760		3-Phase, 240 V	9.6	25.0	43.3	
26B761		3-Phase, 400 V	26.7	15.0	25.9	
26B762		3-Phase, 480 V	38.4	12.5	21.7	
26B763	12	3-Phase, 208 V	10.8	19.3	33.4	14.5 (6.6)
26B764		3-Phase, 240 V	14.4	16.7	28.9	
26B765		3-Phase, 400 V	40.0	10.0	17.3	
26B766		3-Phase, 480 V	57.6	8.3	14.4	

## California Proposition 65

### CALIFORNIA RESIDENTS

 **WARNING:** Cancer and reproductive harm – [www.P65warnings.ca.gov](http://www.P65warnings.ca.gov).



# Graco Standard Warranty

Graco warrants all equipment referenced in this document which is manufactured by Graco and bearing its name to be free from defects in material and workmanship on the date of sale to the original purchaser for use. With the exception of any special, extended, or limited warranty published by Graco, Graco will, for a period of twelve months from the date of sale, repair or replace any part of the equipment determined by Graco to be defective. This warranty applies only when the equipment is installed, operated and maintained in accordance with Graco's written recommendations.

This warranty does not cover, and Graco shall not be liable for general wear and tear, or any malfunction, damage or wear caused by faulty installation, misapplication, abrasion, corrosion, inadequate or improper maintenance, negligence, accident, tampering, or substitution of non-Graco component parts. Nor shall Graco be liable for malfunction, damage or wear caused by the incompatibility of Graco equipment with structures, accessories, equipment or materials not supplied by Graco, or the improper design, manufacture, installation, operation or maintenance of structures, accessories, equipment or materials not supplied by Graco.

This warranty is conditioned upon the prepaid return of the equipment claimed to be defective to an authorized Graco distributor for verification of the claimed defect. If the claimed defect is verified, Graco will repair or replace free of charge any defective parts. The equipment will be returned to the original purchaser transportation prepaid. If inspection of the equipment does not disclose any defect in material or workmanship, repairs will be made at a reasonable charge, which charges may include the costs of parts, labor, and transportation.

**THIS WARRANTY IS EXCLUSIVE, AND IS IN LIEU OF ANY OTHER WARRANTIES, EXPRESS OR IMPLIED, INCLUDING BUT NOT LIMITED TO WARRANTY OF MERCHANTABILITY OR WARRANTY OF FITNESS FOR A PARTICULAR PURPOSE.**

Graco's sole obligation and buyer's sole remedy for any breach of warranty shall be as set forth above. The buyer agrees that no other remedy (including, but not limited to, incidental or consequential damages for lost profits, lost sales, injury to person or property, or any other incidental or consequential loss) shall be available. Any action for breach of warranty must be brought within two (2) years of the date of sale.

**GRACO MAKES NO WARRANTY, AND DISCLAIMS ALL IMPLIED WARRANTIES OF MERCHANTABILITY AND FITNESS FOR A PARTICULAR PURPOSE, IN CONNECTION WITH ACCESSORIES, EQUIPMENT, MATERIALS OR COMPONENTS SOLD BUT NOT MANUFACTURED BY GRACO.** These items sold, but not manufactured by Graco (such as electric motors, switches, hose, etc.), are subject to the warranty, if any, of their manufacturer. Graco will provide purchaser with reasonable assistance in making any claim for breach of these warranties.

In no event will Graco be liable for indirect, incidental, special or consequential damages resulting from Graco supplying equipment hereunder, or the furnishing, performance, or use of any products or other goods sold hereto, whether due to a breach of contract, breach of warranty, the negligence of Graco, or otherwise.

## **FOR GRACO CANADA CUSTOMERS**

The Parties acknowledge that they have required that the present document, as well as all documents, notices and legal proceedings entered into, given or instituted pursuant hereto or relating directly or indirectly hereto, be drawn up in English. Les parties reconnaissent avoir convenu que la rédaction du présente document sera en Anglais, ainsi que tous documents, avis et procédures judiciaires exécutés, donnés ou intentés, à la suite de ou en rapport, directement ou indirectement, avec les procédures concernées.

# Graco Information

For the latest information about Graco products, visit [www.graco.com](http://www.graco.com).

For patent information, see [www.graco.com/patents](http://www.graco.com/patents).

**TO PLACE AN ORDER**, contact your Graco distributor or call to identify the nearest distributor.

**Phone:** 612-623-6921 **or Toll Free:** 1-800-328-0211, **Fax:** 612-378-3505

*All written and visual data contained in this document reflects the latest product information available at the time of publication. Graco reserves the right to make changes at any time without notice.*

Original instructions. This manual contains English. MM 3A8940

**Graco Headquarters:** Minneapolis

**International Offices:** Belgium, China, Japan, Korea

**GRACO INC. AND SUBSIDIARIES • P.O. BOX 1441 • MINNEAPOLIS MN 55440-1441 • USA**  
**Copyright 2022, Graco Inc. All Graco manufacturing locations are registered to ISO 9001.**

[www.graco.com](http://www.graco.com)  
Revision A, May 2022