

Fluid Automation F4 Series

335028H

EN

For metering, mixing, and dispensing multiple component silicone materials.
For professional use only.

Not approved for use in explosive atmospheres or hazardous locations.

Models:

F4-5

F4-55

F4-55-5

See page 4 for model information, including maximum working pressure and approvals.



Important Safety Instructions

Read all warnings and instructions in this manual. Save these instructions.

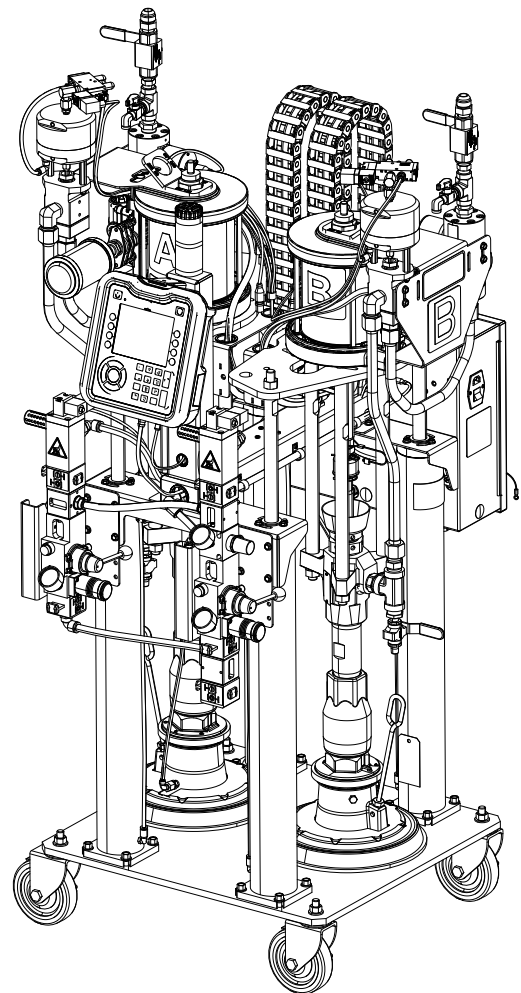

Contents

Related Manuals	3	Operation	44
Models	4	Home Screen Operation	44
Base Machines	4	Color Learning	45
Warnings	5	Ratio Check	46
Component Identification	8	Material Purge	46
F4-5 Model	8	ADM Maintenance Screens	47
F4-55 Model	9	ADM Error Log	48
F4-55-5 Model	10	ADM Event Log	48
Advanced Display Module (ADM)	11	ADM Diagnostics	48
Integrated Air Controls	16	Prime Screen	49
Electrical Enclosure	17	Shutdown	50
Fluid Control Modules	18	Pressure Relief Procedure	50
FCM Component Connection Reference	19	Maintenance	52
Installation	20	Adjust Packing Nuts	52
Lift the Machine	20	Seals	52
Locate and Secure the Machine	20	ADM Battery Replacement and Screen Cleaning	53
Install the Accessories	21	Software Update Procedure	54
Connect the Air Supply Line to the Machine ...	21	Troubleshooting	55
Connect Electrical Power to the Machine	21	Mechanical and Electrical Troubleshooting ...	55
Install the Stack onto the Press	22	Appendix A - ADM Screen Icons	59
Connect the Material Hoses to the Machine ...	22	Appendix B - ADM Error and Event Codes	60
Connect the Air Line from the Machine to the Stack	22	Error Codes	60
Connect the Electrical Signals to the Press ...	23	Event Codes	67
Grounding	23	Appendix C - USB Operation	68
Setup	24	Overview	68
Advanced Display Module	24	USB Options	68
Integrated Air Control Usage	24	USB Logs	68
Load the Material	25	Download Files	69
Prime the Pumps	26	Upload Files	69
Prime the Material Lines	28	Appendix D - Color Limits	70
Connect the Material Lines to the Stack.	30	Schematics	77
Calibrate the Flow Meter	30	Dimensions	81
Material Setup Options	32	Model F4-5	81
Color Setup	33	Model F4-55 and F4-55-5	83
Continuous Level Calibration	37	Technical Data	85
Small Shot Mode	38	California Proposition 65	85
Advanced Settings	40	Graco Standard Warranty	86
Startup	42	Graco Information	86

Related Manuals

Manuals are available at www.graco.com. Component manuals below are in English:

System Manuals	
335029	Fluid Automation F4 Series Instructions - Parts
3A3103	Fluid Automation F4 Series Instructions - Kits-Accessories
3A3171	Fluid Automation F4 Series Fluid Control Module Kit
Ram Manuals	
3A0233	Air-Powered Ram Instructions - Parts
Pump Manuals	
312375	Check-Mate® Displacement Pumps Instructions - Parts
Air Motor Manuals	
3A1211	SaniForce® Air Motors Instructions - Parts
Flow Meter Manuals	
308778	Volumetric Fluid Flow Meter Instructions - Parts
309834	Helical Gear Fluid Flow Meters Instructions - Parts
Reference Manuals	
3A1244	Graco Control Architecture™ Module Programming
Valve Manuals	
313342	Dosing Valve Instructions - Parts

Models









Base Machines

Part No.	Chemical Industry	Description	Ratio (by Weight)	Maximum Working Pressure psi (MPa, bar)
24X160	Silicone	F4-5 System, 5 gallon/5 gallon (20 liter/20 liter) machine	1:1	3000 (21, 207)
24X167		F4-55 System, 55 gallon/55 gallon (200 liter/200 liter) machine with casters		
24X169		F4-55 System, 55 gallon/55 gallon (200 liter/200 liter) machine without casters		
24X166		F4-55-5 System, 5 gallon/5 gallon (20 liter/20 liter) machine with casters		
24X168		F4-55-5 System, 5 gallon/5 gallon (20 liter/20 liter) machine without casters		





 approved.

Warnings

The following warnings are for the setup, use, grounding, maintenance, and repair of this equipment. The exclamation point symbol alerts you to a general warning and the hazard symbols refer to procedure-specific risks. When these symbols appear in the body of this manual or on warning labels, refer back to these Warnings. Product-specific hazard symbols and warnings not covered in this section may appear throughout the body of this manual where applicable.

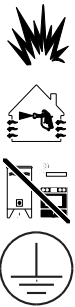
 WARNING	
 	<p>ELECTRIC SHOCK HAZARD</p> <p>This equipment must be grounded. Improper grounding, setup, or usage of the system can cause electric shock.</p> <ul style="list-style-type: none"> • Turn off and disconnect power cord before servicing equipment. • Connect only to grounded electrical outlets. • Use only 3-wire extension cords. • Ensure ground prongs are intact on power and extension cords. • Do not expose to rain. Store indoors
  	<p>SKIN INJECTION HAZARD</p> <p>High-pressure fluid from dispensing device, hose leaks, or ruptured components will pierce skin. This may look like just a cut, but it is a serious injury that can result in amputation. Get immediate surgical treatment.</p> <ul style="list-style-type: none"> • Do not point dispensing device at anyone or at any part of the body. • Do not put your hand over the fluid outlet. • Do not stop or deflect leaks with your hand, body, glove, or rag. • Follow the Pressure Relief Procedure when you stop dispensing and before cleaning, checking, or servicing equipment. • Tighten all fluid connections before operating the equipment. • Check hoses and couplings daily. Replace worn or damaged parts immediately.
 	<p>MOVING PARTS HAZARD</p> <p>Moving parts can pinch, cut or amputate fingers and other body parts.</p> <ul style="list-style-type: none"> • Keep clear of moving parts. • Do not operate equipment with protective guards or covers removed. • Pressurized equipment can start without warning. Before checking, moving, or servicing equipment, follow the Pressure Relief Procedure and disconnect all power sources.

! WARNING

	<p>FIRE AND EXPLOSION HAZARD</p> <p>Flammable fumes, such as solvent and paint fumes, in work area can ignite or explode. Paint or solvent flowing through the equipment can cause static sparking. To help prevent fire and explosion:</p> <ul style="list-style-type: none"> • Use equipment only in well ventilated area. • Eliminate all ignition sources; such as pilot lights, cigarettes, portable electric lamps, and plastic drop cloths (potential static arc). • Ground all equipment in the work area. See Grounding instructions. • Never spray or flush solvent at high pressure. • Keep work area free of debris, including solvent, rags, and gasoline. • Do not plug or unplug power cords, or turn power or light switches on or off when flammable fumes are present. • Use only grounded hoses. • Hold gun firmly to side of grounded pail when triggering into pail. Do not use pail liners unless they are anti-static or conductive. • Stop operation immediately if static sparking occurs or you feel a shock. Do not use equipment until you identify and correct the problem. • Keep a working fire extinguisher in the work area.
	<p>EQUIPMENT MISUSE HAZARD</p> <p>Misuse can cause death or serious injury.</p> <ul style="list-style-type: none"> • Do not operate the unit when fatigued or under the influence of drugs or alcohol. • Do not exceed the maximum working pressure or temperature rating of the lowest rated system component. See Technical Data in all equipment manuals. • Use fluids and solvents that are compatible with equipment wetted parts. See Technical Data in all equipment manuals. Read fluid and solvent manufacturer's warnings. For complete information about your material, request MSDS from distributor or retailer. • Do not leave the work area while equipment is energized or under pressure. • Turn off all equipment and follow the Pressure Relief Procedure when equipment is not in use. • Check equipment daily. Repair or replace worn or damaged parts immediately with genuine manufacturer's replacement parts only. • Do not alter or modify equipment. Alterations or modifications may void agency approvals and create safety hazards. • Make sure all equipment is rated and approved for the environment in which you are using it. • Use equipment only for its intended purpose. Call your distributor for information. • Route hoses and cables away from traffic areas, sharp edges, moving parts, and hot surfaces. • Do not kink or over bend hoses or use hoses to pull equipment. • Keep children and animals away from work area. • Comply with all applicable safety regulations.
	<p>TOXIC FLUID OR FUMES HAZARD</p> <p>Toxic fluids or fumes can cause serious injury or death if splashed in the eyes or on skin, inhaled, or swallowed.</p> <ul style="list-style-type: none"> • Read SDSs to know the specific hazards of the fluids you are using. • Store hazardous fluid in approved containers, and dispose of it according to applicable guidelines.
	<p>PERSONAL PROTECTIVE EQUIPMENT</p> <p>Wear appropriate protective equipment when in the work area to help prevent serious injury, including eye injury, hearing loss, inhalation of toxic fumes, and burns. Protective equipment includes but is not limited to:</p> <ul style="list-style-type: none"> • Protective eyewear, and hearing protection. • Respirators, protective clothing, and gloves as recommended by the fluid and solvent manufacturer

 **WARNING****PRESSURIZED ALUMINUM PARTS HAZARD**

Use of fluids that are incompatible with aluminum in pressurized equipment can cause serious chemical reaction and equipment rupture. Failure to follow this warning can result in death, serious injury, or property damage.

- Do not use 1,1,1-trichloroethane, methylene chloride, other halogenated hydrocarbon solvents or fluids containing such solvents.
- Do not use chlorine bleach.
- Many other fluids may contain chemicals that can react with aluminum. Contact your material supplier for compatibility.

**BURN HAZARD**

Equipment surfaces and fluid that's heated can become very hot during operation. To avoid severe burns:

- Do not touch hot fluid or equipment.

Component Identification

F4-5 Model

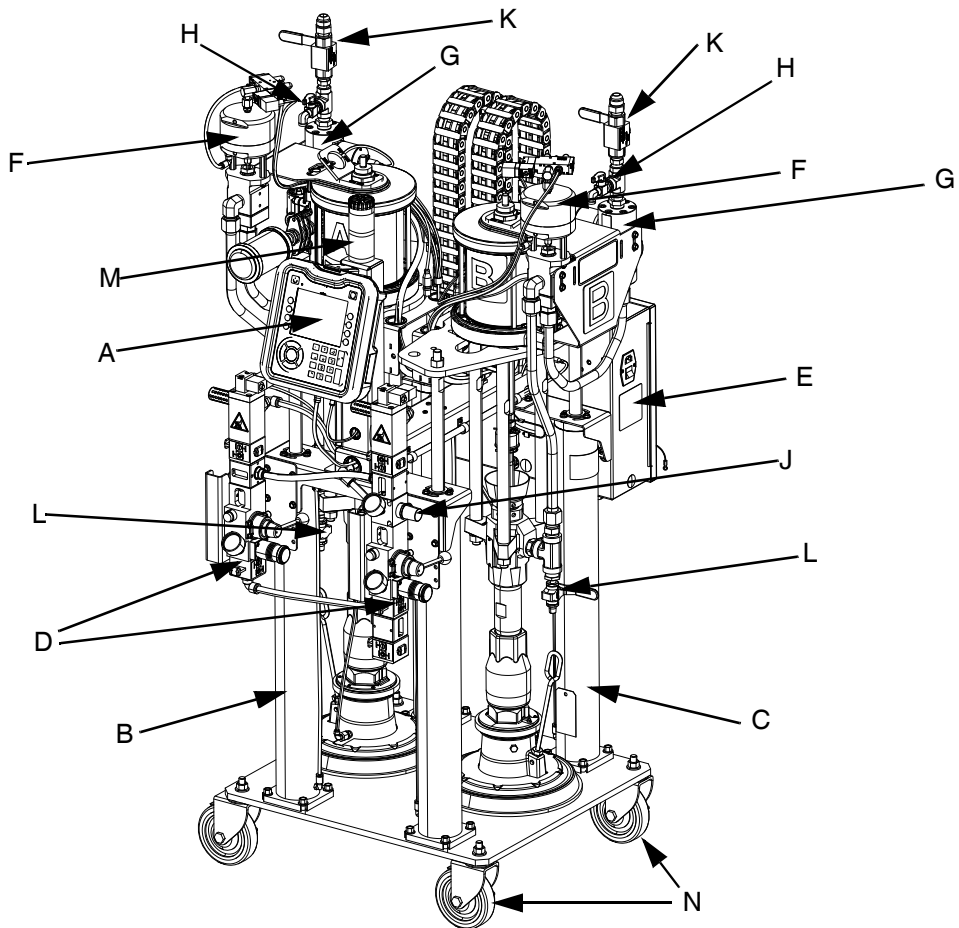

FIG. 1: F4-5 Model

Key:

- A Advanced Display Module (ADM)
- B Ram - A Chemical
- C Ram - B Chemical
- D Integrated Air Controls
- E Electrical Enclosure
- F Dosing Valve
- G Flow Meters
- H Ratio Check Ball Valves
- J Air Motor Regulator Adjustment
Controls the pressure to the base (A) and catalyst (B) air motors.
- K Material Outlet Ball Valves
- L Prime Ball Valves
- M Light Tower
- N Casters

F4-55 Model

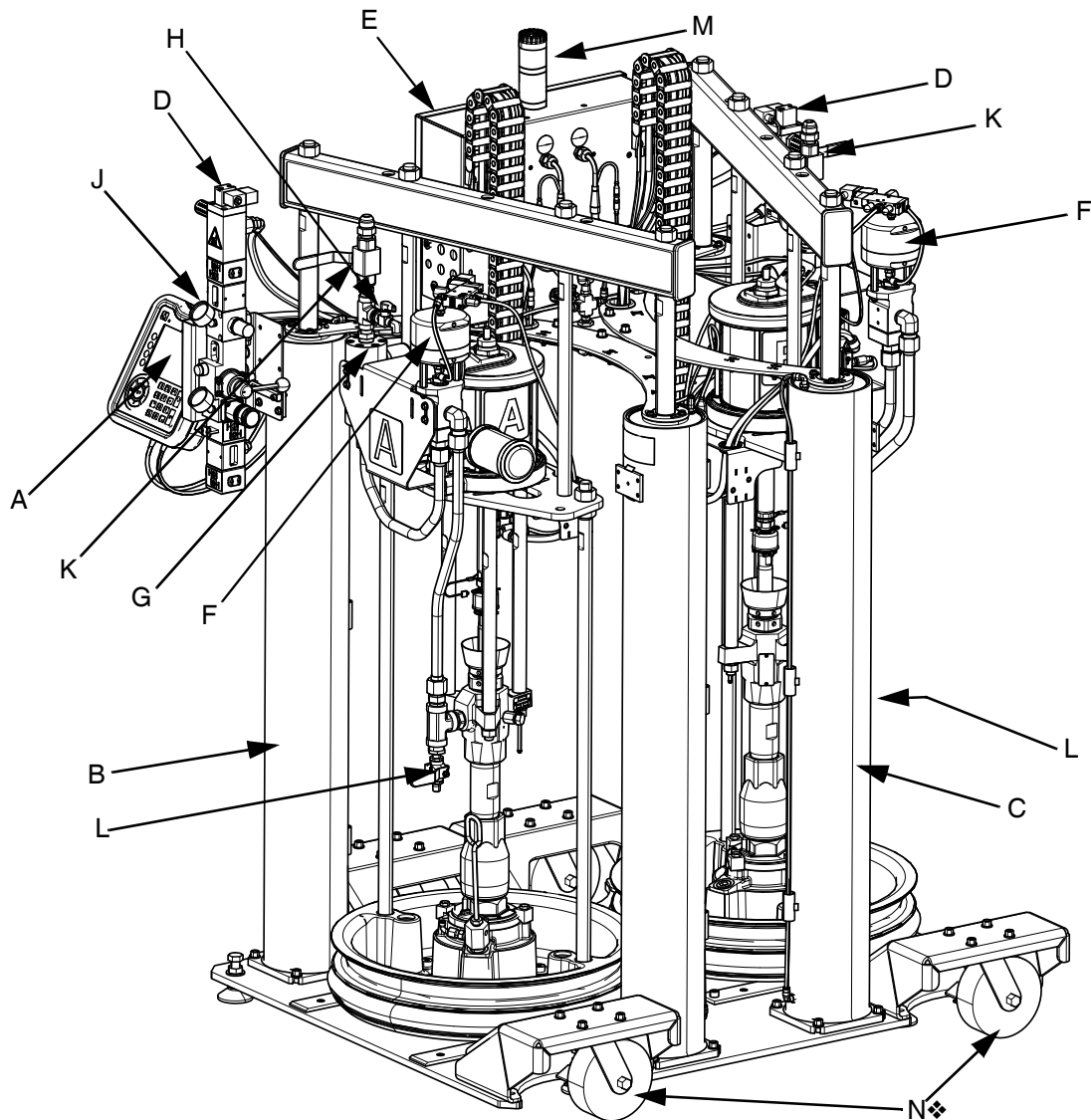

FIG. 2: F4-55 Model

NOTE: Refer to the key found on page 8.

- ❖ *F4-55 models are offered with or without casters installed. Part number 24X167 includes casters. Part number 24X169 does not include casters. There is an optional caster kit (part no. 24X218) available for attaching casters to 24X169. See the Fluid Automation F4 Series Kits-Accessories manual for information about installing the caster kit. Refer to Related Manuals on page 3.*

F4-55-5 Model

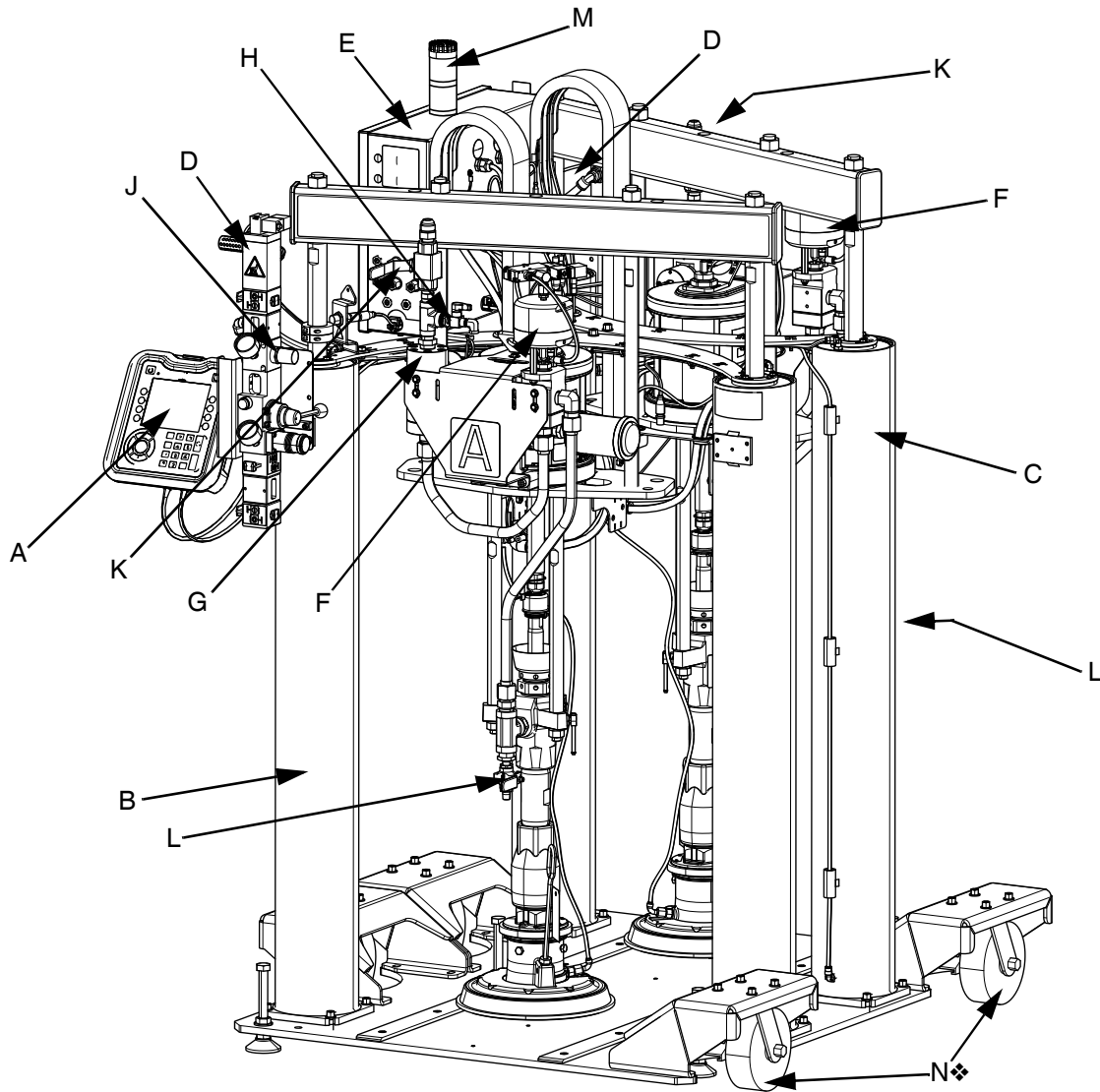

Fig. 3: F4-55-5 Model

NOTE: Refer to the key found on page 8

- ❖ *F4-55-5 models are offered with or without casters installed. Part number 24X166 includes casters. Part number 24X168 does not include casters. There is an optional caster kit (part no. 24X218) available for attaching casters to 24X168. See the Fluid Automation F4 Series Kits-Accessories manual for information about installing the caster kit. Refer to Related Manuals on page 3.*

Advanced Display Module (ADM)

Front and Rear Views

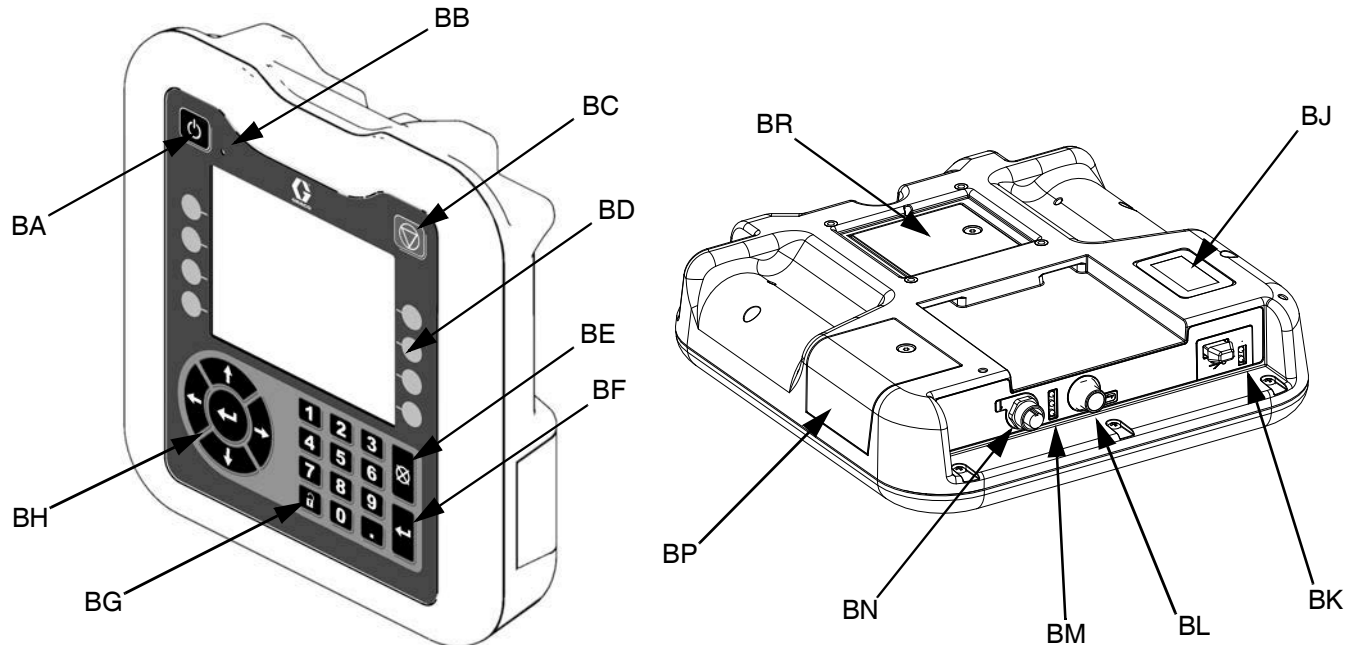

FIG. 4: ADM Component Identification

Key:

BA System Enable/ Disable

Enables/disables the system. When the system is disabled, the dispense operation is disabled.

BB System Status Indicator Light

BC System Soft Stop

Stops all system processes and disables the system.

BD Soft Keys

Defined by the icon on the screen next to the soft key.

BE Cancel

Cancel a selection or number entry while in the process of entering a number or making a selection. Cancels all system processes.

BF Enter

Accept change, acknowledge error, select item, and toggle selected item.

BG Lock/Setup

Toggle between run and setup screens.

BH Directional Keypad

Navigate within a Screen or to a New Screen

BJ Part Number Identification Label

BK USB Interface

BL CAN Cable Connection

Power and communication.

BM Module Status LEDs

Visual indicators to show the status of the ADM:

Green Solid - Power provided.

Green Off - No power.

Yellow Flashing - Communication with other GCA devices occurring.

Red Solid - Bad ADM or machine is in critical status.

Red Flashing - Wrong program uploaded.

BN Light Tower Connection

BP Token Access Cover

Access cover for software token.

BR Battery Access Cover

Main Display Components

The following figure calls out the navigational, status, and general informational components of the ADM screens.

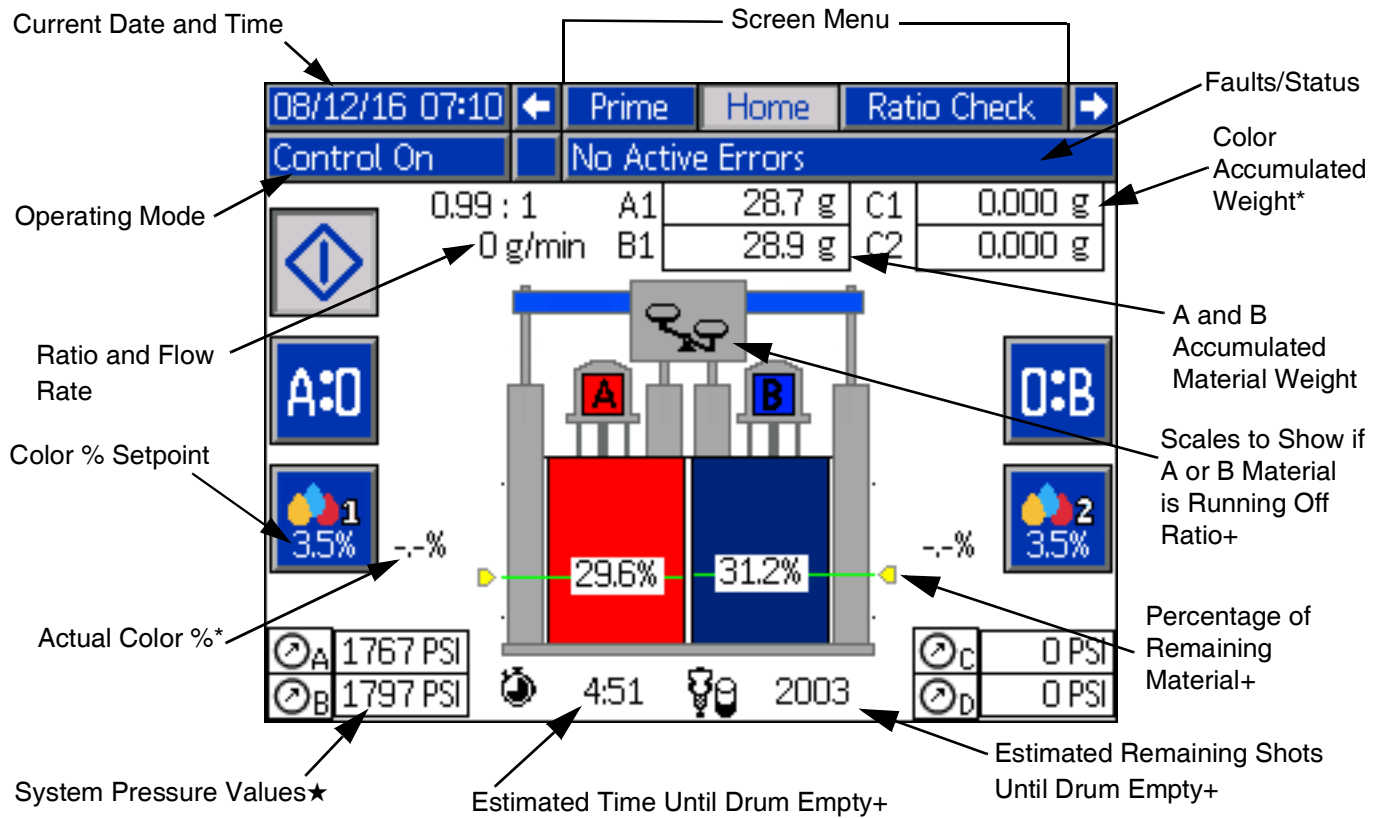

FIG. 5: ADM Main Display Components

* Only displayed when using a color flow meter that is enabled at the Color Setup screen (see page 35).

+ Only displayed when using continuous level sensors that are enabled at the Drum Level screen (see page 37).

★ Only displayed when using pressure transducers that are enabled at Advanced screen 3 (see page 41) or the Small Shot Setup Screen (see page 38).

ADM Control Modes

Operating Mode	Description	Component Status
System Off	The system does not have power.	<ul style="list-style-type: none"> No system status indicator LED on ADM Light tower is off Material pumps are off Color injectors (optional) are off
Machine Off	The machine is powered on, but not turned on. No action can be taken in this mode.	<ul style="list-style-type: none"> Solid yellow system status indicator LED on ADM Light tower is off Material pumps are off Color injectors (optional) are off
Control Off	The machine is powered on and turned on.	<ul style="list-style-type: none"> Solid green system status indicator LED on ADM Light tower is off Material pumps are off Color injectors (optional) are off

Operating Mode	Description	Component Status
Control On	The machine is running and waiting for the screw rotate (Go) signal.	<ul style="list-style-type: none"> • Solid green system status indicator LED on ADM • Light tower is solid green • Material pumps are on • User-selected color injectors (optional) are on
Prime	The pump is running in prime mode (See page 26).	<ul style="list-style-type: none"> • Solid green system status indicator LED on ADM • Light tower is flashing green • User-selected material pumps are on • Color injectors (optional) are off
Purge A	Ready to purge pump A (See page 46).	<ul style="list-style-type: none"> • Solid green system status indicator LED on ADM • Light tower is flashing green • Material pump A is on • Color injectors (optional) are off
Purge B	Ready to purge pump B (See page 46).	<ul style="list-style-type: none"> • Solid green system status indicator LED on ADM • Light tower is flashing green • Material pump B is on • Color injectors (optional) are off
Ratio Check	The machine is performing a ratio check (See page 46).	<ul style="list-style-type: none"> • Solid green system status indicator LED on ADM • Light tower is flashing green • Material pumps are on • Color injectors (optional) are off
Color Calibration	The machine is running color calibration (See page 35).	<ul style="list-style-type: none"> • Solid green system status indicator LED on ADM • Light tower is flashing green • Material pumps are off • User-selected color injectors (optional) are on
Material Calibration	The machine is running material flow meter calibration (See page 30).	<ul style="list-style-type: none"> • Solid green system status indicator LED on ADM • Light tower is flashing green • User-selected material pump is on • Color injectors (optional) are off
Alarm State	The machine goes to a safe condition.	<ul style="list-style-type: none"> • Solid green system status indicator LED on ADM • Light tower is flashing red • Material pumps are off • Color injectors (optional) are off
Advisory State	The machine continues operation in Control On, Purge A or Purge B modes.	<ul style="list-style-type: none"> • Solid green system status indicator LED on ADM • Light tower is flashing green • Material pumps status depends on operating mode • Color injectors (optional) status depends on operating mode
Small Shot	The machine is running in small shot mode within a set pressure band and waiting for the screw rotate (Go) signal.	<ul style="list-style-type: none"> • Solid green system status indicator LED on ADM • Light tower is solid green • Material pumps are on • User-selected color injectors (optional) are on

ADM Screen Navigation Diagram

The black arrows in the diagram below denote which arrow on the directional keypad to press to move to the respective screen.

Refer to Figure 4, ADM Component Identification on page 11 for the location of the directional keypad arrows and the other keys on the ADM.

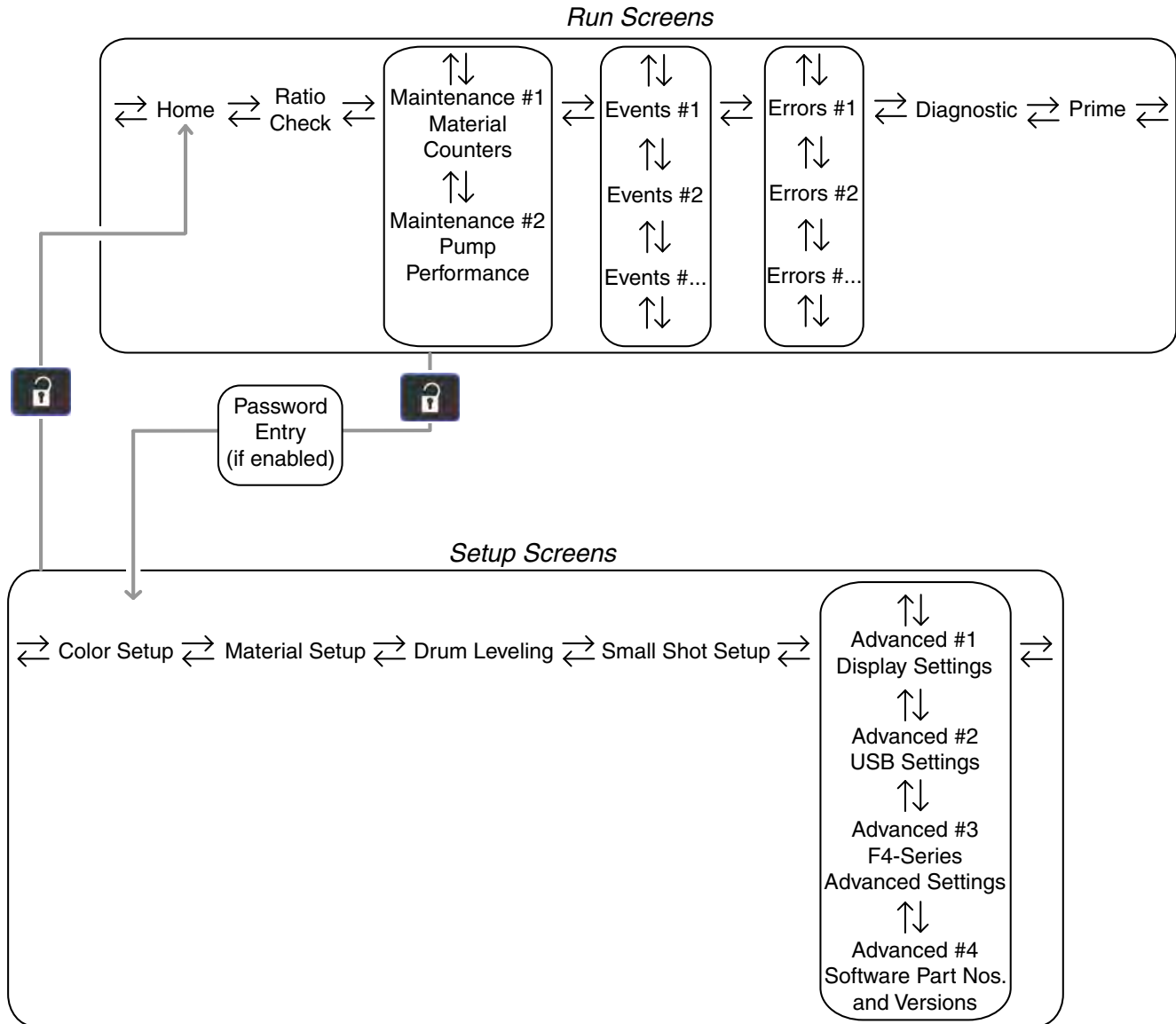

FIG. 6: ADM Screen Navigation

Integrated Air Controls

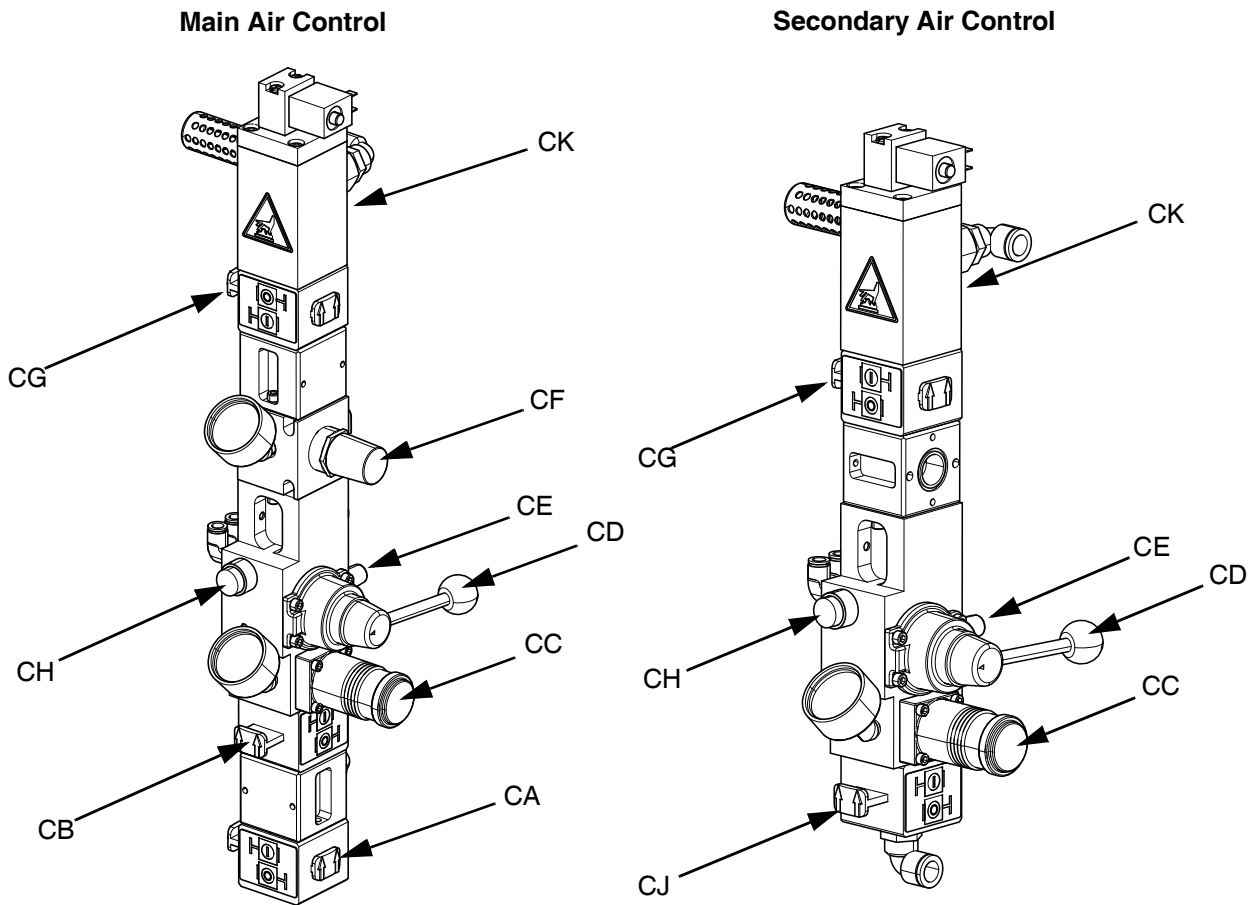

FIG. 7: Integrated Air Controls

Key:

CA System Air Slider Valve

Turns air on and off to the entire system. When closed, the valve prevents any incoming air from the air supply.

CB Main Air Slider Valve

Turns air on and off to the main air control. When closed, the valve relieves pressure downstream.

CC Ram Air Regulator

Controls the ram up and down pressure and blow-off pressure.

CD Ram Director Valve

Controls the ram direction.

CE Exhaust Port with Muffler

CF Air Motor Regulator

Controls the air pressure to the motors (A and B).

CG Air Motor Slider Valve

Turns air on and off to the air motor. When closed, the valve relieves air trapped between it and the motor.

CH Blow off Button

Turns air on and off to push the platen out of an empty drum.

CJ Secondary Air Slider Valve

Turns air on and off to the secondary air control. When closed, the valve relieves pressure downstream.

CK Air Motor Solenoid

Turns air off to the air motors in the event of a pump runaway.

Electrical Enclosure

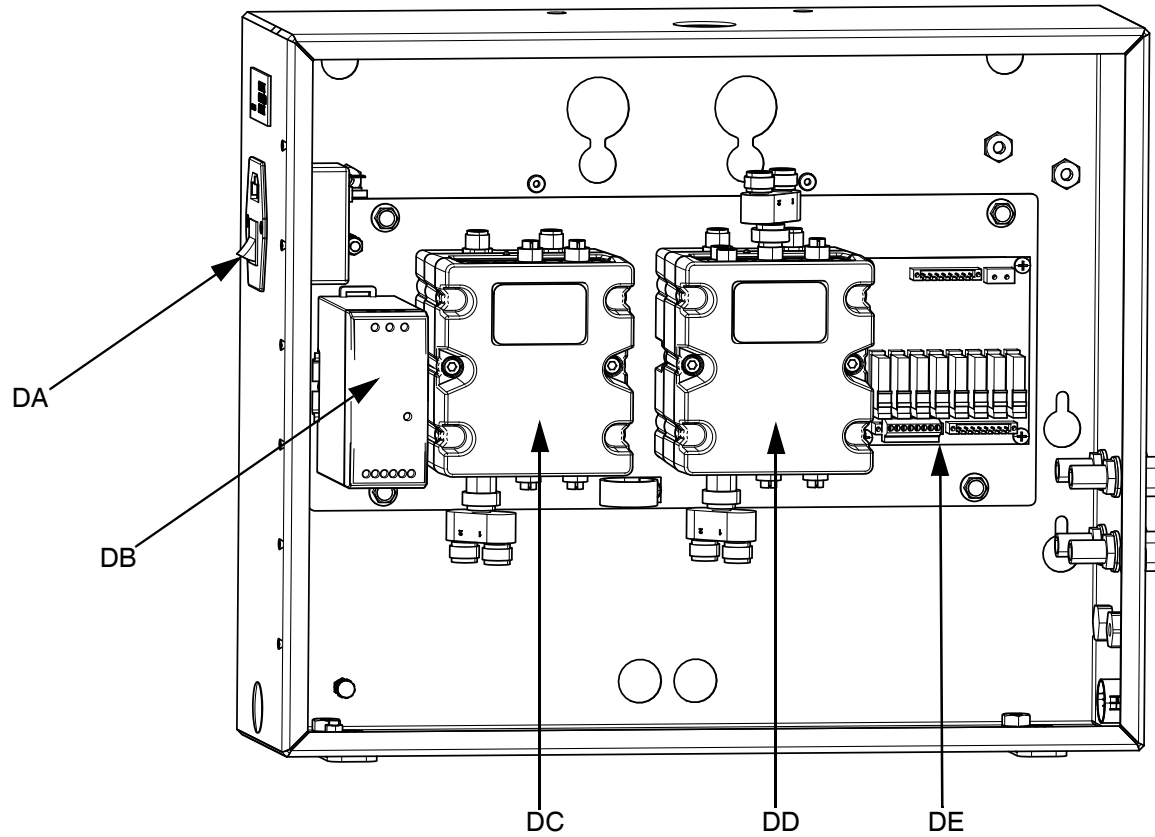

FIG. 8: Electrical Enclosure

Key:

- DA Power Switch**
Turns electrical power on or off.
- DB 24VDC Power Supply**
Converts input power to 24 VDC.
- DC FCM #1**
Fluid Control Module
- DD FCM #2**
Fluid Control Module
- DE Relay Board**
Relays (Go, Ready, Fault, Purge)

Fluid Control Modules

The F4 Series has two Fluid Control Modules. See Figure 8 for the location of each in the Electrical Enclosure.

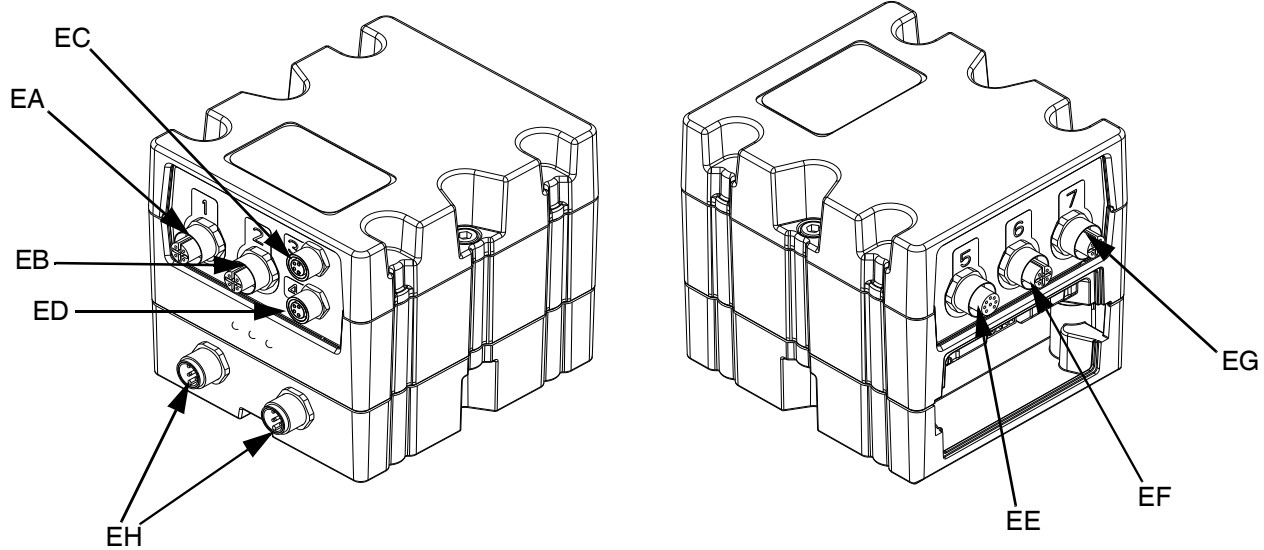

Fig. 9: FCM #1 and #2 Connections

Key:

ID	Connections	FCM #1	FCM #2
EA	Port 1	B Side (1) Dosing Valve Solenoid* (2) Flow Meter* Go #1 Signal from FCM to the Relay Board	Purge Signal #1 Ready Signal #1 Purge Signal #2 Ready Signal #2
EB	Port 2	A Side (1) Dosing Valve Solenoid* (2) Flow Meter* Go #2 Signal from FCM to the Relay Board	Fault Signal Color Flow Meter #1 Color Flow Meter #2
EC	Port 3	Stack #1 Solenoid Valves (A) and (B)	Continuous Level Sensor (B) - Optional*
ED	Port 4	Stack #2 Solenoid Valves (A) and (B) - optional	Continuous Level Sensor (A) - Optional*
EE	Port 5	Low Level Sensors (A) and (B) Color Injector #1 - Optional Color Injector #2 - Optional	(1) Air Control Solenoid (A) and (B)* (2) Air Motor Reed Switch*
EF	Port 6	Pressure C❖	Pressure A❖
EG	Port 7	Pressure D❖	Pressure B❖
EH	CAN Connection	Supplies power and communications to GCA components	Supplies power and communications to GCA components

* These connections are referenced in Figure 10 on page 19.

❖Used with Small Shot for LSR Kit 25C237.

FCM Component Connection Reference

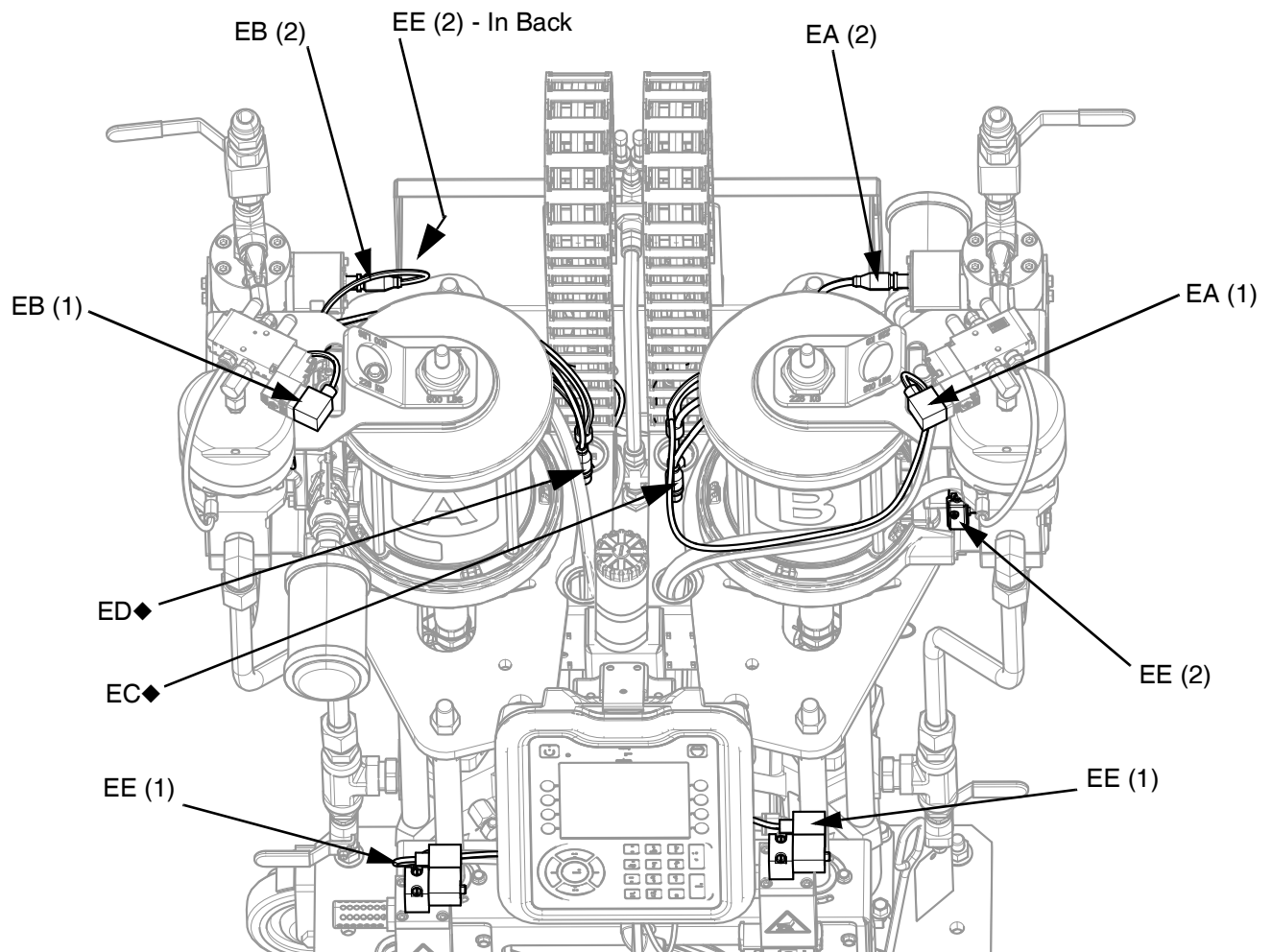

FIG. 10: FCM Component Connections

Refer to the key for Figure 9 on page 18.

- ◆ These cables are labeled "E" and are typically tied to the A and B air motors when the machine is shipped.

Installation



Moving parts can pinch or amputate fingers. To avoid personal injury, do not supply air to the machine while making the air supply connections. Do not pressurize the system until you have verified the system is ready and it is safe to do so.

NOTICE

Apply POLY-TEMP[®] ceramic tape or equivalent to all National Pipe Threads (NPTs) when installing.

Lift the Machine

The F4-5, F4-55, and F4-55-5 machines can all be lifted by a forklift when available. Make sure you always lift the machine from the bottom when unloading from the shipping container or moving the machine.

F4-55 and F4-55-5 Lifting with a Crane

When it is necessary to lift these machines by a crane, follow these steps:

1. Ensure the ram director valves on the air controls are in the neutral position for both rams.

2. Wrap two slings, one under each top ram cross beam and around both pump tie rods for each ram.

NOTE: The slings must be equal length.

3. Connect the slings to the crane and lift the machine off the shipping container.
4. When you are done moving the machine, remove the cross brace from the ram cross beam and save it for later use.

Locate and Secure the Machine

1. Locate the machine on a level surface. See **Dimensions** starting on page 81 for space requirements.

NOTE: On the F4-55 and F4-55-5, adjust the jack screws to ensure the machine is level.

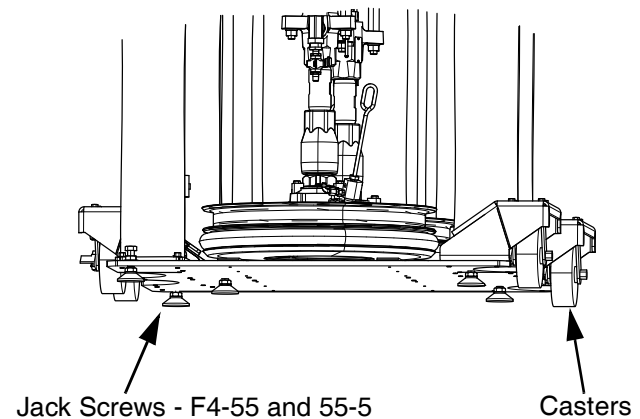
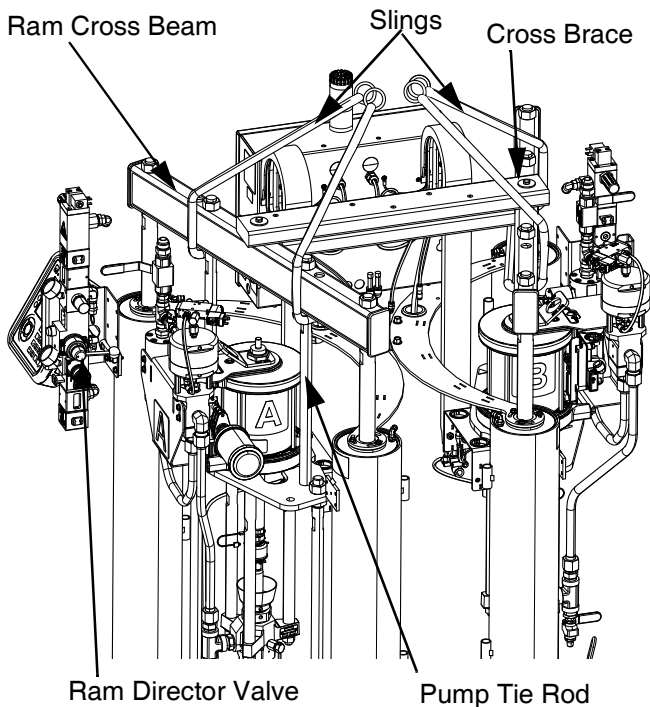

- Lock the casters to prevent the machine from moving.

NOTE: F4-55 and F4-55-5 models are offered with or without casters installed. If you have a model without casters, a caster kit, part no. 24X218, is available. See the Fluid Automation F4 Series Kits-Accessories manual for information about installing the caster kit. Refer to Related Manuals on page 3.

Install the Accessories

For installing kits and accessories, see the Fluid Automation F4 Series Kits-Accessories manual. Refer to Related Manuals on page 3.

The electrical enclosure comes pre-wired inside the enclosure. All cables to the press and accessories, such as the stack and color injector, are connected at the lower right side of the enclosure, on the outside.

The locations for the connections are clearly labeled for ease of use.

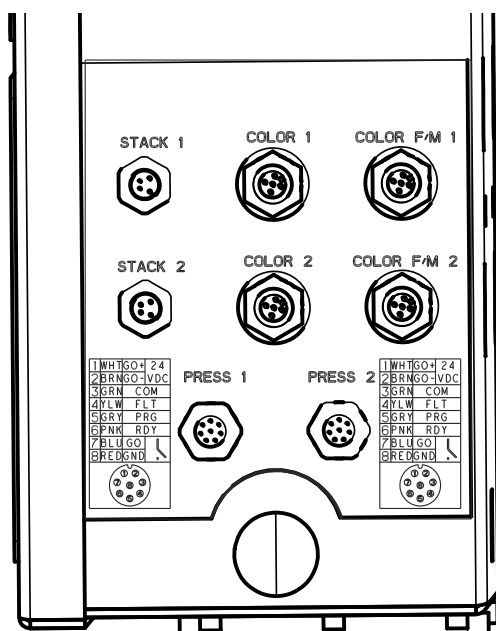

Connect the Air Supply Line to the Machine

The main air control has a 1/2 in. npt (F) connection located at the bottom for connecting the air supply line.

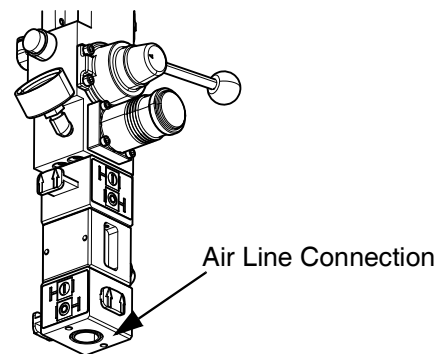

NOTE: A minimum 1/2 in. inside diameter (ID) air line is recommended.

Connect Electrical Power to the Machine

Connect the power cord included with the machine to the electrical enclosure directly above the power switch. The power supply can be 95-264 V, 50/60 Hz.

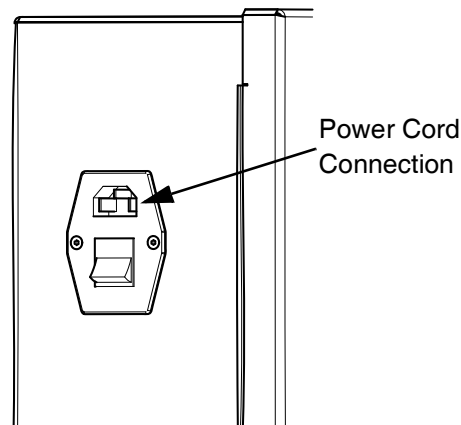

Install the Stack onto the Press

NOTE: Installation can vary depending on the type of stack being used. See the Fluid Automation F4 Series Kits-Accessories manual for information. Refer to Related Manuals on page 3.

Connect the Material Hoses to the Machine

The material hose connections at the machine are JIC-12 flared connections.

NOTE: Use the optional JIC-08 fitting adapter kit 26B164 for 1/2 in. hoses. See the Fluid Automation F4 Series Instructions - Kits-Accessories manual. Refer to Related Manuals on page 3.

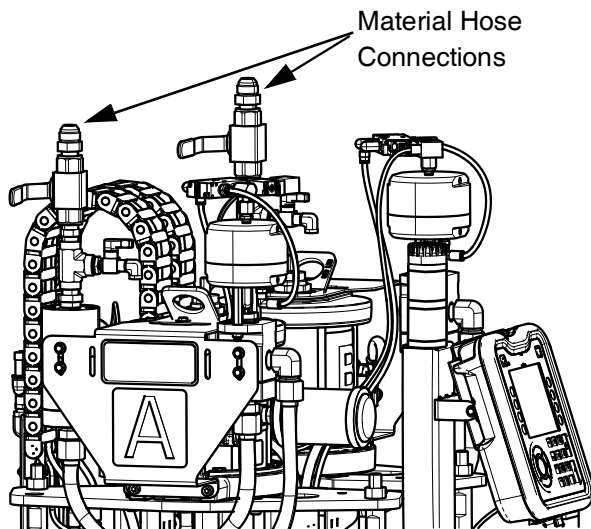

NOTE: Do NOT connect the material hoses to the stack at this time. The pumps and material lines must be primed before the material hoses are connected to the stack. Refer to **Setup**, starting on page 24, for information regarding these priming procedures and when the material hoses should be connected to the stack.

Connect the Air Line from the Machine to the Stack

NOTE: The 3/8 in. tubing that is required for providing pressurized air to the stack is included with the stack.

- a. Remove one of the 3/8 in. plugs from the air line ports at the machine and connect the tubing to the ports.

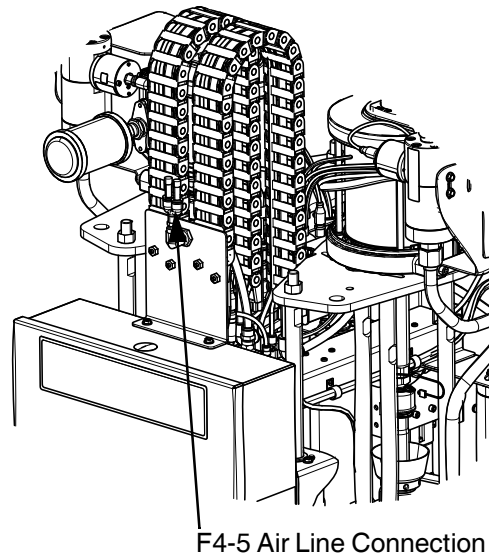

- b. Run the 3/8 in. air line tubing from the machine to the stack and connect it to the air inlet on the stack.

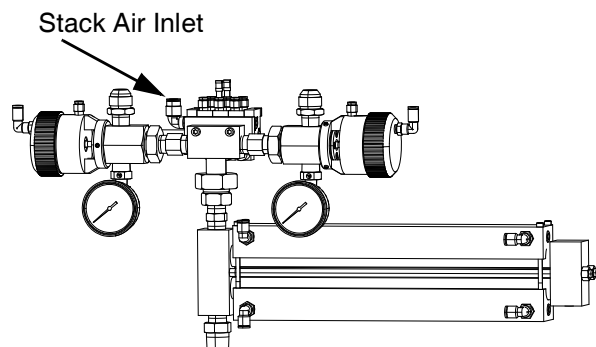

NOTE: If using the dual stack kit 25A102 the 3/8 in. tee included with the kit should be used for the air line connection at the machine.

NOTE: Stack 24R681 is shown. See the Fluid Automation F4 Series Kits-Accessories manual for other stacks available for use with the F4 Series. Refer to Related Manuals on page 3. All F4 Series stacks have the same connections for the air lines.

Connect the Electrical Signals to the Press

Connect the wiring from the electrical enclosure to the press using the following table as a reference.

Press Signal Connections (Ports 1 and 2)			
1	WHT	GO +	24 VDC
2	BRN	GO -	
3	GRN	COM	
4	YLW	FLT	
5	GRY	PRG	
6	PNK	RDY	
7	BLU	GO	
8	RED	GND	

- COM - Common
- FLT - Fault
- PRG - Purge
- RDY - Ready

NOTE: The F4 Series machines have one of two options for the Screw Rotate (Go) signal: 24 VDC or dry contact. Before connecting the machine to the press, verify which signal is coming from the press and use one of the two options based on the requirements from the press manufacturer.

Grounding

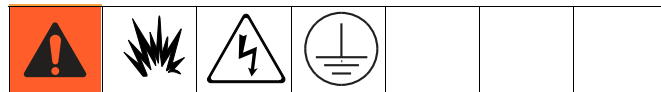

The equipment must be grounded to reduce the risk of static sparking and electric shock. Electric or static sparking can cause fumes to ignite or explode. Improper grounding can cause electric shock. Grounding provides an escape wire for the electric current.

Machine: grounded through customer supplied power cord.

Fluid supply container: follow local code.

Solvent pails used when flushing: follow local code. Use only conductive metal pails, placed on a grounded surface. Do not place the pail on a non-conductive surface, such as paper or cardboard, which interrupts grounding continuity.

To maintain grounding continuity when flushing or relieving pressure: hold metal part of the spray gun/dispense valve firmly to the side of a grounded metal pail, then trigger the gun/valve.

Setup



NOTICE

To prevent damage to soft key buttons, do not press the buttons with sharp objects such as pens, plastic cards, or fingernails.

Advanced Display Module

When the main electrical power is turned on, the Graco splash screen is displayed until communication and initialization is complete.



To begin using the ADM, the machine must be on and enabled. To verify the machine is enabled, the System Status Indicator Light (see Figure 4 on page 11) must be illuminated green. If the indicator light is not green,

press . The System Status Indicator Light illuminates yellow if the machine is disabled. See **ADM Control Modes** on page 12 for more information.

Integrated Air Control Usage

The F4 models have two integrated air controls: one main air control and one secondary air control.

The main air control has three valves for controlling the air supply:

- System Air Slider Valve - controls the air supply to the entire system.
- Main Air Slider Valve - controls the air supply to the main air control.
- Air Motor Slider Valve - controls the air supply to the air motor.

The secondary air control has two valves for controlling the air supply:

- Secondary Air Slider Valve - controls the air supply to the secondary air control.
- Air Motor Slider Valve - controls the air supply to the air motor.

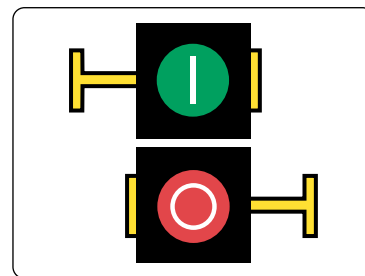

The air supply at each of these valves is turned on and off by sliding the valve horizontally. Labels have been applied next to these valves showing when the valve is turned on and when it is turned off.





The green icon represents the valve being turned on, which allows air flow. The red icon represents the valve being turned off, which prevents air flow. Throughout this manual, arrows are used to show the direction the slider valves should be pushed to turn on or turn off the air flow.

See Figure 7 on page 16 for information on all of the integrated air control components.

Load the Material

						
<p>To avoid personal injury or machine damage, adjust all air regulators counter-clockwise prior to turning the system air supply on and ensure all valves are in the OFF (Closed) position.</p>						

						
<p>Moving parts can pinch or amputate fingers. When the pump is operating and when raising or lowering the ram, keep fingers and hands away from the pump intake, platen, and lip of the drum.</p>						

1. Turn on the air supply to the machine by sliding the system air slider valve on the main air control.

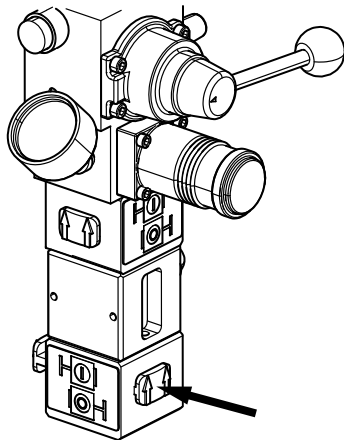

2. Turn on the main air slider valve.

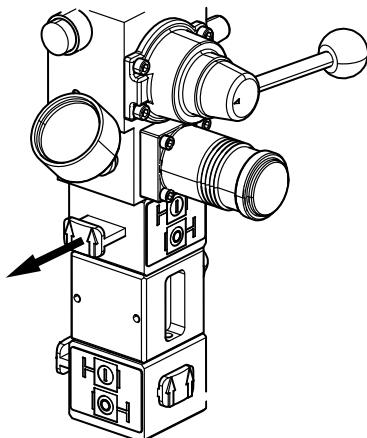

3. Set the ram air regulator on the main air control to 10-20 psi for the F4-5, 50 psi for the F4-55, and 5-10 psi for the F4-55-5.

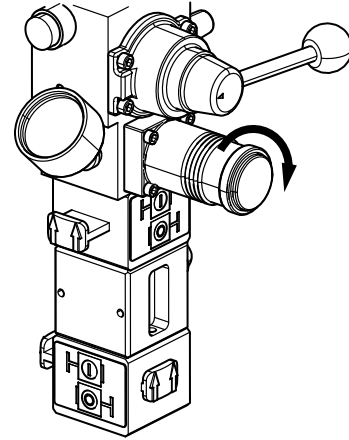

4. Lift the ram director valve handle to raise the ram to full height.

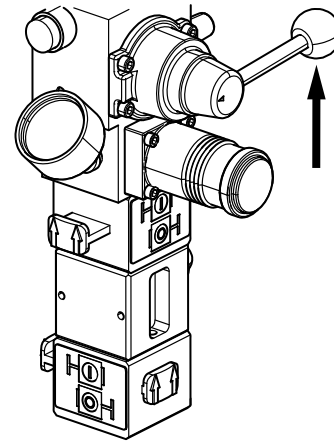

NOTICE

To avoid damage to the platen seals, do not use a drum that is dented or damaged.

NOTICE

If the drum containing the material you are using has a plastic liner, pull it over the edge of the drum. Then secure it around the outside circumference of the drum so the plastic does not get pulled into the drum during operation.

- Lube the ram platen o-rings with the material from the drum.

NOTICE

Do not mix materials when lubricating the drums. Use the A material to lubricate the A side drum and the B material to lubricate the B side drum.

- Place the full drum on the machine's base and center it under the platen.

NOTE: Model F4-55 has screws in the base that act as drum stops. Slide the barrels against the drum stops.

NOTICE

Ensure that there is no debris on the platen to avoid damage to the platen seal and debris mixing with the material.

- Remove the bleed stick from the ram.

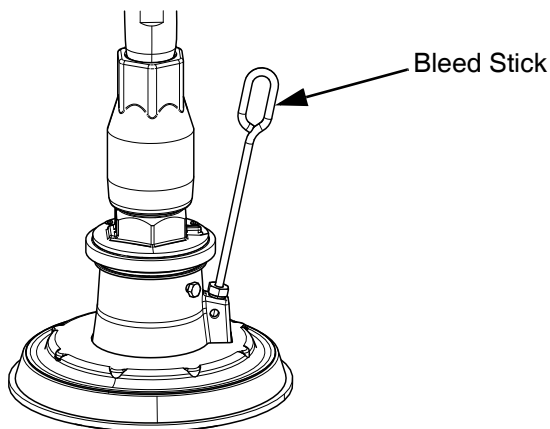

- Move the ram director valve handle down to lower the ram into the drum until material appears at the top of the bleed port.

- Replace the bleed stick and clean off any excess material that overflowed from the bleed port.

- Adjust the ram pressure as needed.

Repeat this procedure for the other material drum using the secondary air control. See Figure 7 on page 16 for the location of the secondary air slider valve.

Prime the Pumps

To avoid personal injury or machine damage, do not exceed 25 psi on the material until a steady flow of material has been established.						

NOTE: Ensure that the material outlet ball valves are closed and that the air motor slider valves on both the main and secondary air controls are in the off (closed) position prior to starting this procedure.

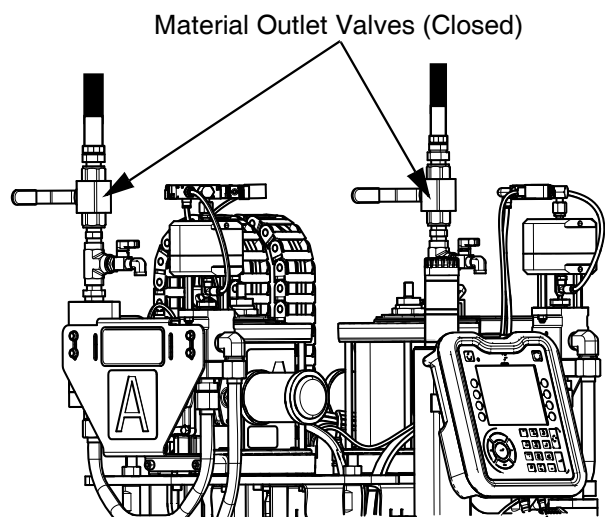

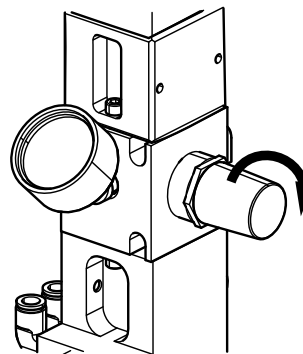

- Set the air motor regulator on the main air control to 10 psi.

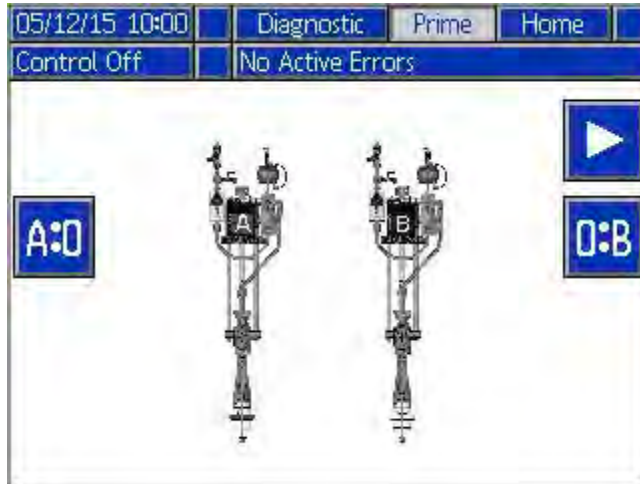

- Press  to enable the ADM. Use the right or left arrow key to navigate to the Prime screen in the Menu Bar at the top of the display.



- Press the  key to select the A side prime.

- Press the  key to start the A side prime.



NOTE: Both the A:0 and 0:B pumps can be run at the same time.

- Open the A prime ball valve (turn the handle down) and hold an empty container below it.

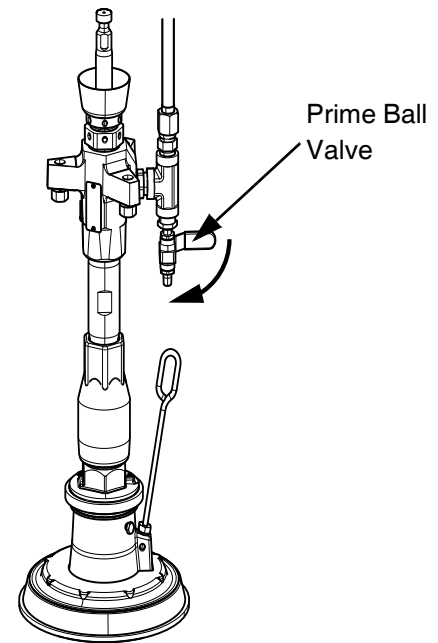

- Turn on the air motor slider valve on the A pump side air control.

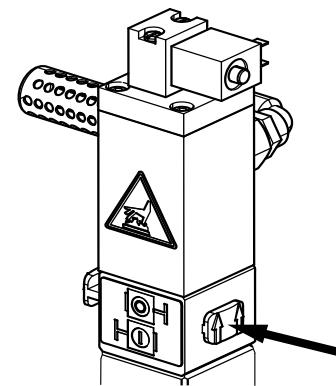

- Let the material run into the empty container until you get a steady stream with no air trapped in the line. Then close the prime ball valve.

- Turn off the air motor slider valve on the A pump side.

- Press the  key to deactivate the A side prime.

- Repeat steps 3-9 for the B side prime.

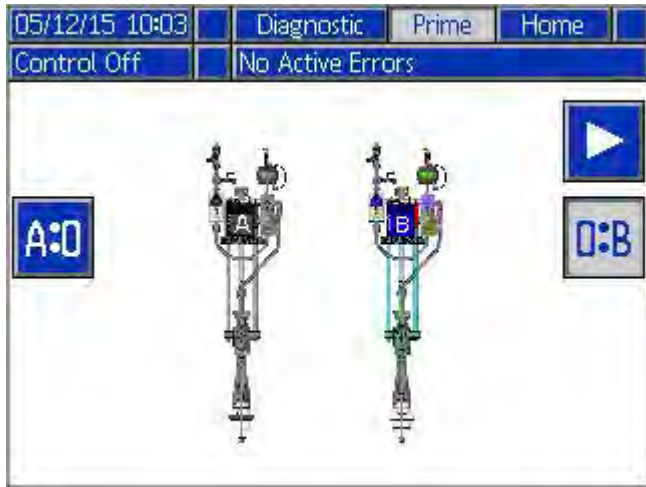

Prime the Material Lines

<p>To avoid personal injury or machine damage, adjust the air motor regulator counter-clockwise prior to turning the main air on.</p>						

- Turn off the air motor slider valves on both the main and secondary air controls. These slider valves are the ones closest to the top of the air controls.

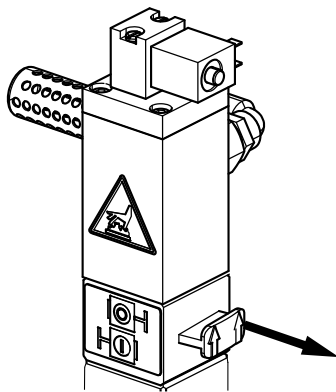

NOTE: Ensure the ratio check ball valves on both the A and B side are closed.

NOTE: Ensure the material outlet hoses are connected to both the A and B material outlet ball valves, but are not connected to the stack.

- Open both of the material outlet ball valves.

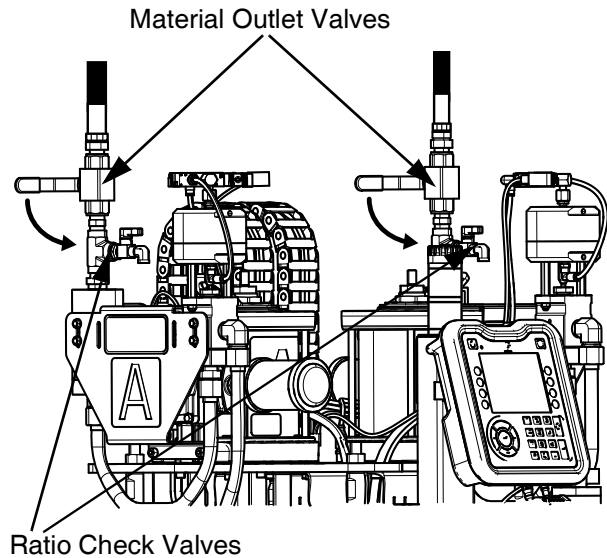

- Turn on the system air slider valve (1) and then turn on the main air slider valve (2).

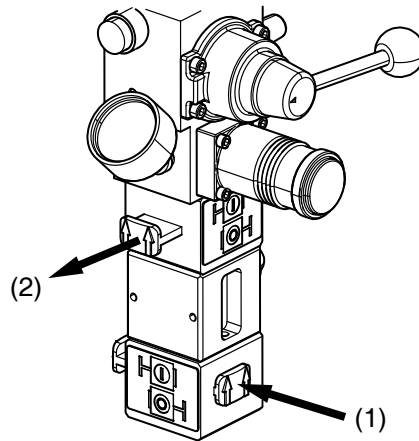

- Set the air motor regulator to 10 psi (70 kPa 0.7 bar).

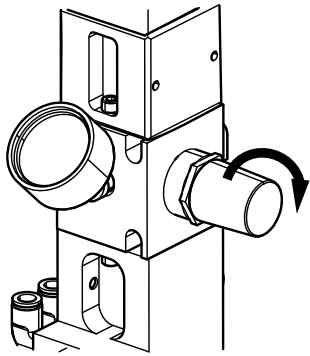

--	--	--	--	--	--

To avoid personal injury or machine damage, do not exceed 25 psi on the material until a steady flow of material has been established.

- Place the A side material hose inside a waste container.
- Use the right or left arrow key to navigate to the Prime setup screen in the Menu Bar.

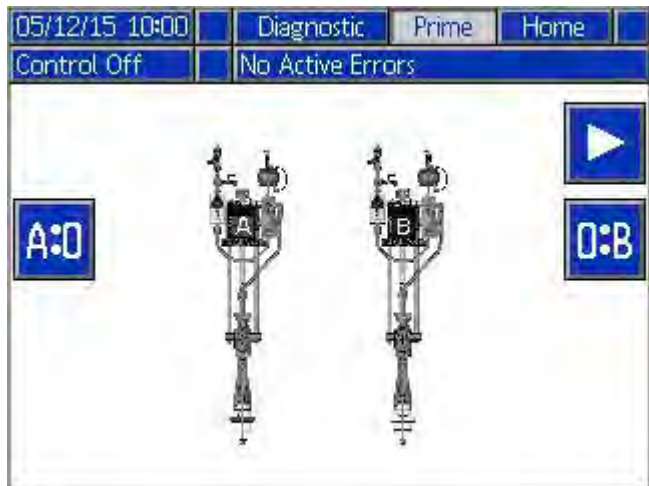

- Press the key to select the A side prime.
- Press the key to enable the A side prime.



- Turn on the air motor slider valve on the A pump side air control.

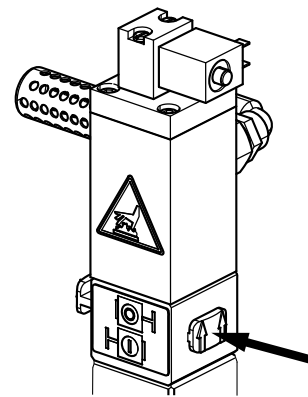

- Increase the air motor regulator as needed to have the material flow out of the hose and into the waste container until the hose is purged and free of air.
- Press the key to stop the A side prime.
- Turn off the air motor slider valve on the A pump side air control.

- Repeat steps 1-12 for the B side material outlet hose.

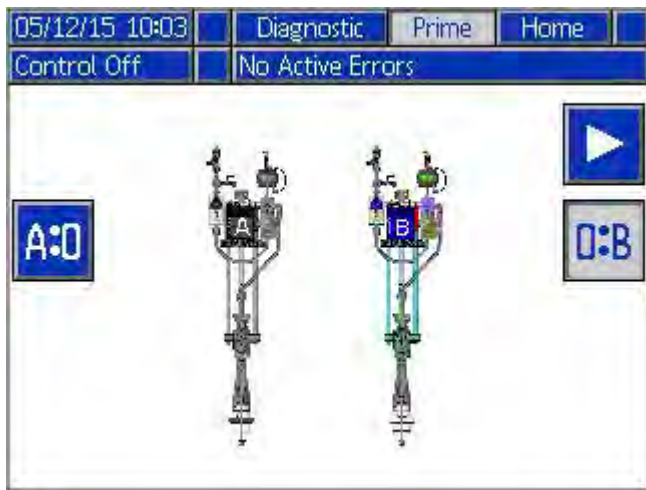

Connect the Material Lines to the Stack.

After the pumps and material lines have been primed, connect both the A and B material outlet hoses to the stack.

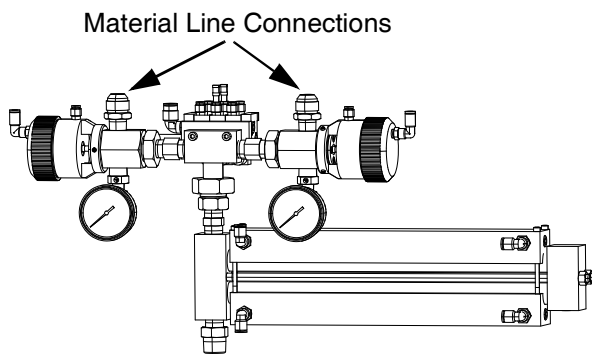

NOTE: Stack 24R681 is shown. See the Fluid Automation F4 Series Kits-Accessories manual for other stacks available for use with the F4 Series. Refer to Related Manuals on page 3. All F4 Series stacks have the same connections for the material lines.

Calibrate the Flow Meter

NOTICE

An empty container should always be placed under the ratio check valve opening before using it to keep the material from dispensing onto the machine.

NOTE: The machine has default flow meter calibration values based on general silicone material with a Specific Gravity (s.g.) of 1.12. Calibration of the flow meters is required for better accuracy of the flow meter.



NOTE: All air must be purged from the machine (pump, dosing valves, flow meter, and hoses) to ensure accurate ratio checks. Trapped air in the system may give inaccurate results. See **Prime the Pumps** on page 26.

NOTE: Ensure that air is turned on to the machine.

NOTE: During calibration processes, the weight of all material must be entered into the ADM in grams.

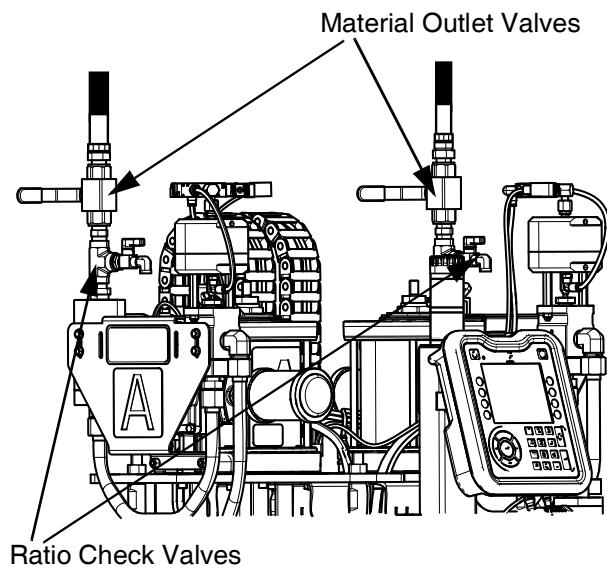
- Close the material outlet valves to the stack on both the A and B sides.



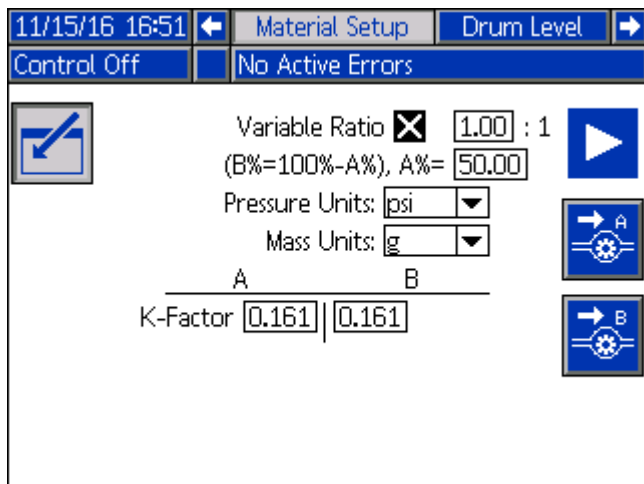

- On the ADM, press  to access the setup screens. Then, use the right or left arrow key to navigate to the Material Setup screen in the Menu Bar.
- Press the  key to enter the screen to make changes.

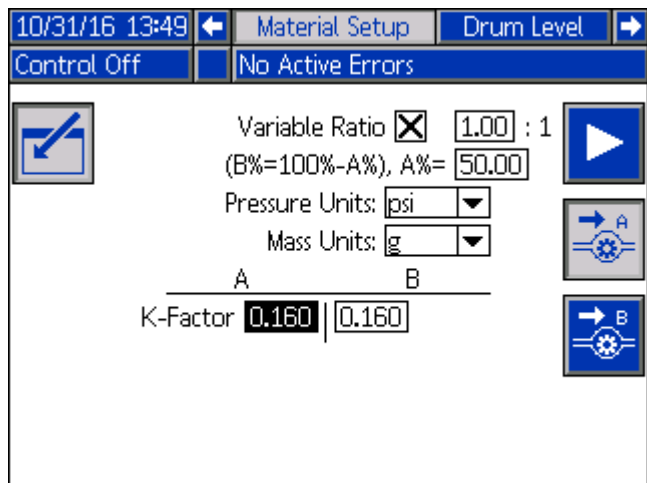

NOTE: The mass unit can show in either grams or kilograms but you must still enter material weight in grams.

4. Tare an empty container on a scale and place the tared container under the A ratio check ball valve.
5. Open the A ratio check valve.
6. Press the  key for the A side flow meter calibration.



7. Press the  key to start the material calibration. The dosing valve opens and closes automatically, dispensing material into the empty container. A progress bar showing the status of the calibration sequence is displayed during the process.
8. The system stops automatically when dispensing is completed. Close the A ratio check valve.

9. Weigh the material that was dispensed and enter the weight in grams in the pop-up box at the Material Setup screen.

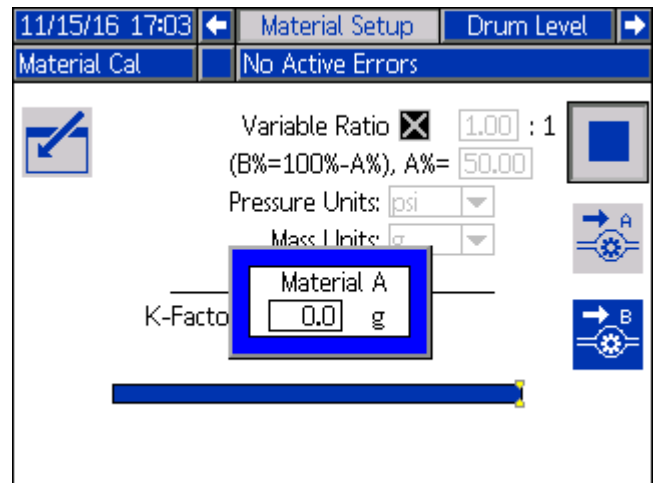

10. Once you have entered the weight, the K-factor updates from the default value if there is a change.

NOTE: The approximate range for the material flow meter K-Factor is 0.134 x s.g. (minimum) to 0.164 x s.g. (maximum) of the material.

11. Repeat steps 4-10 for the B side calibration.

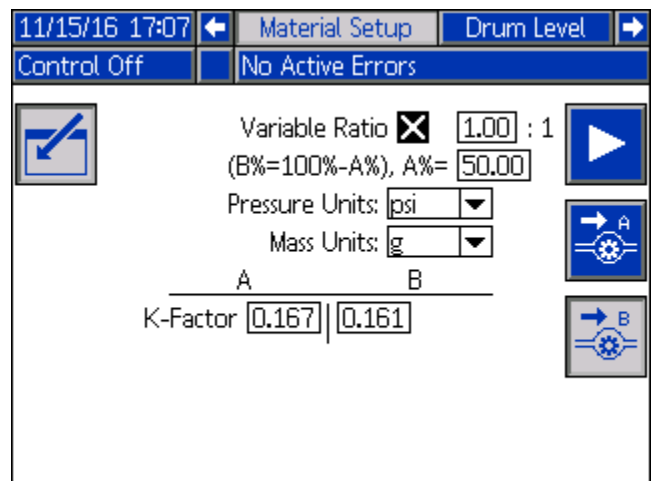

NOTE: Close both ratio check valves when finished.

Material Setup Options

Set the Variable Ratio

A variable ratio feature is available on the Material Setup screen for applications that require using more of one material than the other.

NOTE: You can set the variable ratio by entering either a ratio setting or a material percentage for material A.

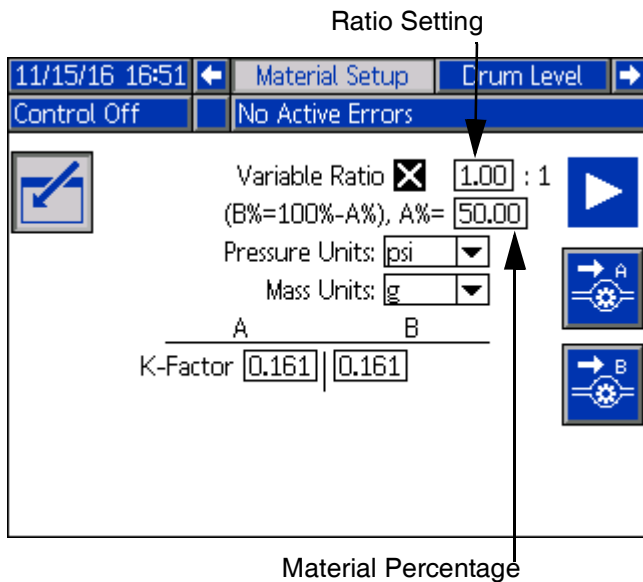

1. Press the  key to enter the screen to make changes.
2. Select the Variable Ratio check box to turn on this feature and to enable the ratio setting and material percentage fields.
3. To enter a ratio setting, use the arrow keys to move to the ratio setting field next to the Variable Ratio check box. This setting is for material A and is used as the control to adjust the ratio. The B material setting remains at 1.
4. Use the numeric keypad to adjust the A material ratio setting to a value between 0.80 and 1.20 to meet the specific needs of your application.
5. To enter a material percentage instead of a ratio setting, use the arrow keys to move to the material percentage field directly below the ratio setting field.
6. Use the numeric keypad to enter the material percentage for A. Refer to the conversion table on this page to determine the correct percentage.

NOTE: When you enter either the ratio setting or the material percentage, the other field automatically fills in the value that corresponds with your entry.

For example, to achieve an 18 gram shot that uses 8 grams of material A and 10 grams of material B, change the setting to 0.80 or enter a material percentage of 44.44. The material ratio then shows as 0.80:1 and the percentage shows as 44.44% for material A.

7. When you are finished making changes, exit the screen using the  key.

The conversion table below shows the available variable ratio settings and the corresponding A and B material percentages.

Conversion Table		
A:1	A%	B%
0.80	44.44	55.56
0.81	44.75	55.25
0.82	45.05	54.95
0.83	45.36	54.64
0.84	45.65	54.35
0.85	45.95	54.05
0.86	46.24	53.76
0.87	46.52	53.48
0.88	46.81	53.19
0.89	47.09	52.91
0.90	47.37	52.63
0.91	47.64	52.36
0.92	47.92	52.08
0.93	48.19	51.81
0.94	48.45	51.55
0.95	48.72	51.28
0.96	48.98	51.02
0.97	49.24	50.76
0.98	49.49	50.51
0.99	49.75	50.25
1.00	50.00	50.00
1.01	50.25	49.75
1.02	50.50	49.50
1.03	50.74	49.26
1.04	50.98	49.02
1.05	51.22	48.78
1.06	51.46	48.54
1.07	51.69	48.31

1.08	51.92	48.08
1.09	52.15	47.85
1.10	52.38	47.62
1.11	52.61	47.39
1.12	52.83	47.17
1.13	53.05	46.95
1.14	53.27	46.73
1.15	53.49	46.51
1.16	53.70	46.30
1.17	53.92	46.08
1.18	54.13	45.87
1.19	54.34	45.66
1.20	54.55	45.45

Change Pressure Units

If you are in small shot mode or monitoring pressure elsewhere at the machine using pressure transducers, you can choose which pressure unit to use when displaying values.

1. Press the  key to enter the screen to make changes.
2. At the Pressure Units field, select one of the three pressure units from the drop down menu: psi, bar, or Mpa.

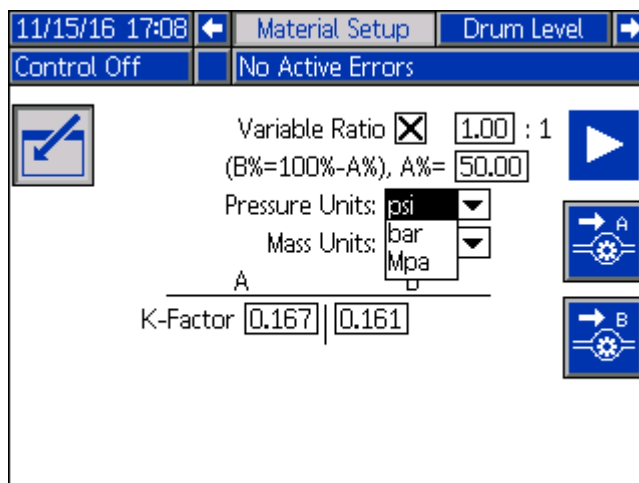

3. When you are finished making changes, exit the screen using the  key.

For information about setting up small shots, see **Small Shot Mode** on page 38.

Color Setup

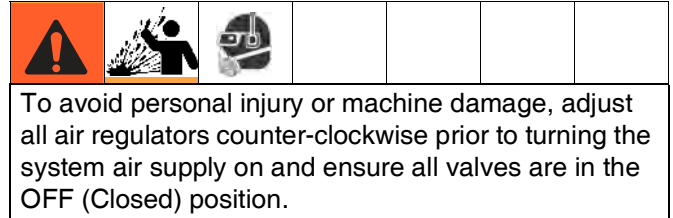

Fill the Colorant Tank

NOTE: See the Fluid Automation F4 Series Kits-Accessories manual for information about connecting the colorant tanks to the machine. Refer to Related Manuals on page 3.

4. Turn the air pressure regulator on top of the tank in a counter-clockwise direction. Ensure the regulator is set at 0 psi.
5. Lift the pressure relief ring at the top of the tank before removing screws from the tank cover to ensure there is no pressure in the tank.

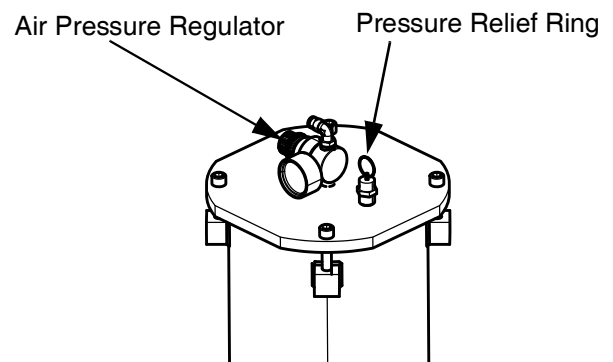

6. Lift off the cover and lubricate or glue (using RTV) the o-ring located in the groove on the bottom of the cover.
 7. Lift the colorant platen out of the tank.
- NOTE:** The platen is used in most applications except those involving materials with very low viscosity.
8. Stir the pigment to the manufacturer requirements.
 9. Pour or scoop the colorant into the colorant feed tank, filling it to the desired level. When filling the tank, leave room for the platen.
 10. Place the platen on top of the colorant with the head of the screw facing up.

11. Place the colorant tank cover back on the tank. Be sure to seat the o-ring into the groove before tightening the screws on the cover.
12. Adjust the colorant tank regulator to the desired pressure.

Prime the Color Injector

NOTE: Priming and calibrating the color injector should be performed prior to connecting the color injector to the stack and after changing color or refilling from empty.

1. Attach the color line to the color injector using the quick disconnect. The disconnect has a check mechanism on both sides to prevent colorant from pouring out when not attached.

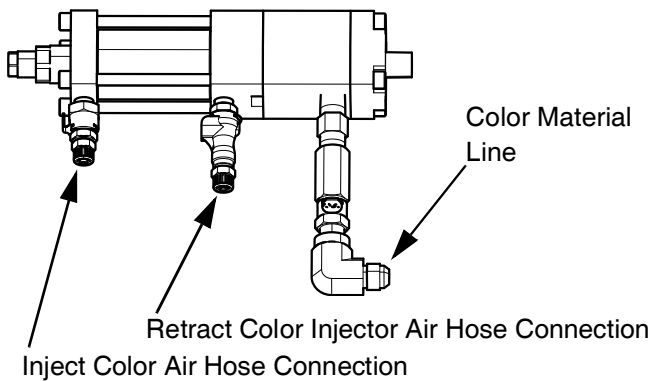

2. Connect the air hoses from the color injector to the injector solenoid.

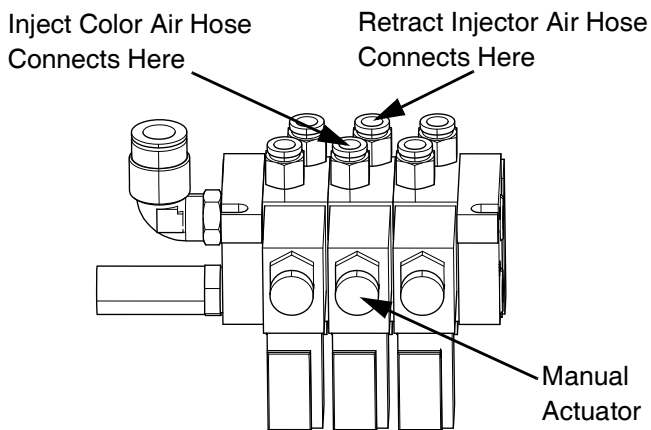

3. At the color injector solenoid on the stack, press and lock the manual actuator to the inject position.

NOTE: See the Fluid Automation F4 Series Kits-Accessories manual for the models of stacks available for use with the F4 Series. Refer to Related Manuals on page 3. All stacks have the same air hose connections from the color injector.

4. Open the color tank ball valve.

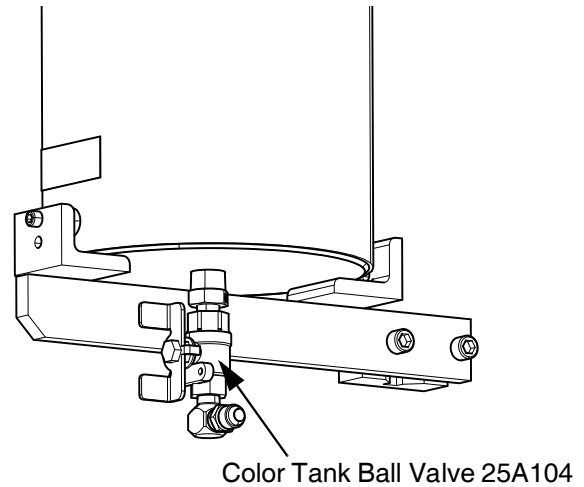

NOTE: When bleeding air from the color injector, some color material also will bleed out. It is best to place a 1/4 inch tube over the bleed valve or wrap a cloth around the valve during this procedure.

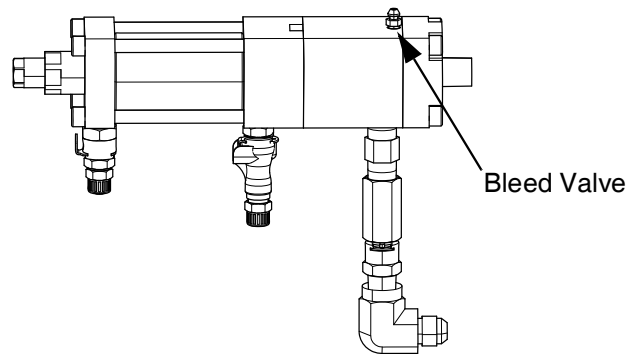



5. Open the bleed valve to force out air from the injector with the color injector bleed valve facing up.
6. Close the bleed valve when it appears that all of the air has been purged.
7. Unlock the manual actuator on the color injector solenoid to return the injector to the proper state.
8. Cycle the injector five times into a waste container by pressing the manual actuator button to ensure all of the air is out.

Calibrate the Color Injector and Color Flow Meter

NOTE: See the Fluid Automation F4 Series Kits-Accessories manual for additional information about these options. Refer to Related Manuals on page 3.

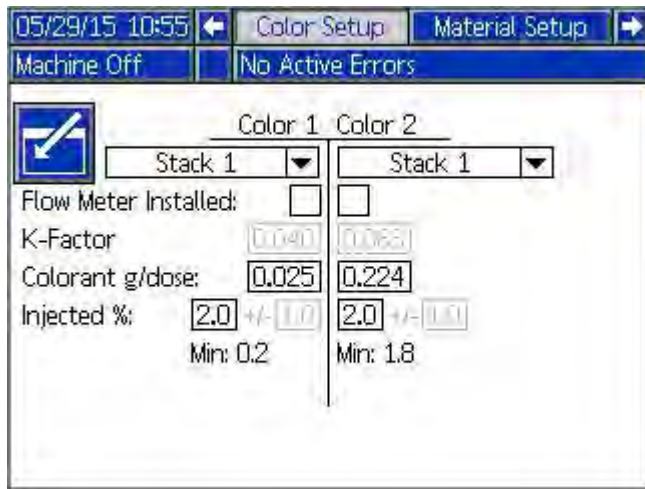
1. On the ADM, press  to access the setup screens. Use the right or left arrow key to navigate to the Color Setup screen in the Menu Bar.



2. Press the  key to enter the Color Setup screen to make changes.
3. If a color flow meter is installed, check the Flow Meter Installed box on the Color Setup screen.

NOTE: Only check the Flow Meter Installed box if you are using a color flow meter.



4. The color injector needs to be adjusted to the correct injector setting based on the system flow rate. At the injector setting adjustment, 0 turns in represents the largest stroke length, while 11 turns in represents the smallest stroke length.

NOTE: See **Appendix D - Color Limits** on page 70 for charts showing the color limits based on the injector setting and system flow rate.

NOTE: The color injector should be operated at the maximum stroke length possible.

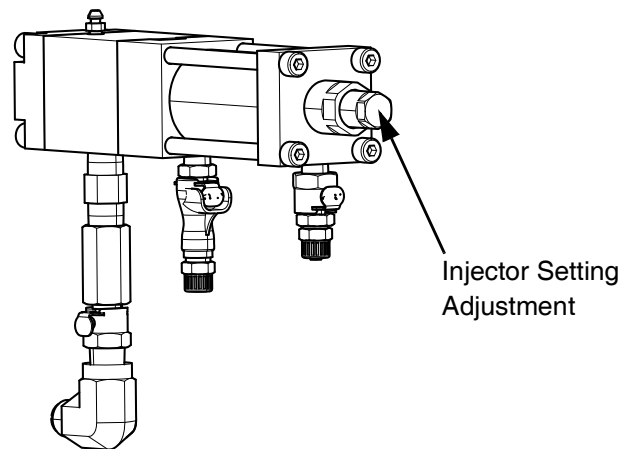



5. Press the  key to calibrate the color 1 injector and/or the color flow meter.

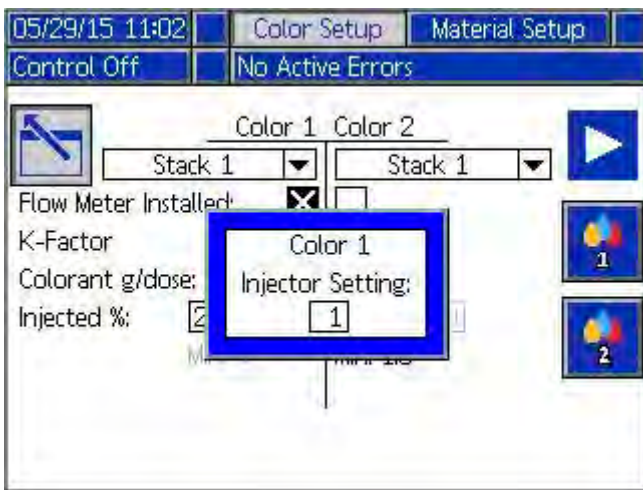

6. Enter the Injector setting in the pop up box on the screen.



7. Tare an empty container on a scale. Then place the container so the color injector dispenses into it.
8. Press the  key. The injector activates and dispenses into the empty tared container. A progress bar shows the status of the calibration sequence during the process. The number of injections for the progress bar depends on the injector setting.
9. When the dispense process is completed, weigh the dispensed color material. Enter the weight into the Color 1 pop up box on the ADM and press .

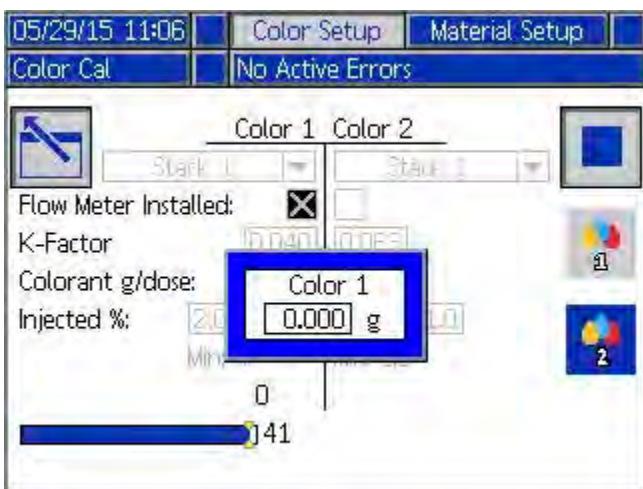



NOTE: The weight must be entered in grams.

10. After the weight is entered, the colorant K-Factor and/or g/dose values automatically update.

NOTE: The approximate range for the color flow meter K-Factor is 0.058 x s.g (minimum) to 0.067 x s.g. (maximum) when a G3000 HR (part no. 289814) flow meter is used.

11. If using two colors, repeat steps 3-9 for color 2.

12. Press the  key to exit the Color Setup screen when you have completed the process.

13. Press  to exit the setup screens.

NOTE: If a higher viscosity color material is used, a G3000 (part no. 289813) flow meter can be used in place of the standard G3000 HR. The range for the G3000 K-Factor would be 0.113 x s.g. (minimum) to 0.125 x s.g. (maximum).

Set the Color Stack and Color Percentage

Prior to operating the machine, you need to return to the Color Setup screen to select the correct stack and appropriate color setup.

1. Press the  key to enter the Color Setup screen.
2. Select Stack 1 or 2 for the color injector being used.
3. Set the Injected % to be between 0.2 and 6%. See **Appendix D - Color Limits** on page 70 for reference information about the injector setting.



When using the color flow meter, you can set the percentage of setpoint error (+/- located to the right of the Injected %) between 0.2 to 6%. If the color deviates more than this setpoint error, it will initiate an alarm and stop the machine.

NOTE: The color deviation alarm starts monitoring after 50 grams of A and B material has passed through the flow meter.

You can view the amount of A and B accumulated material at the counters on the Home screen. See **Main Display Components** on page 12.

Continuous Level Calibration

The optional continuous level sensors must be installed prior to performing this calibration. See the Fluid Automation F4 Series Kits-Accessories manual for information about installing these sensors. Refer to Related Manuals on page 3.

NOTE: It is important to perform the steps for the calibration of the level sensors in the following order to ensure accurate measurement.

1. On the ADM, press  to access the Setup screens. Use the right or left arrow key to navigate to the Drum Level screen in the Menu Bar.

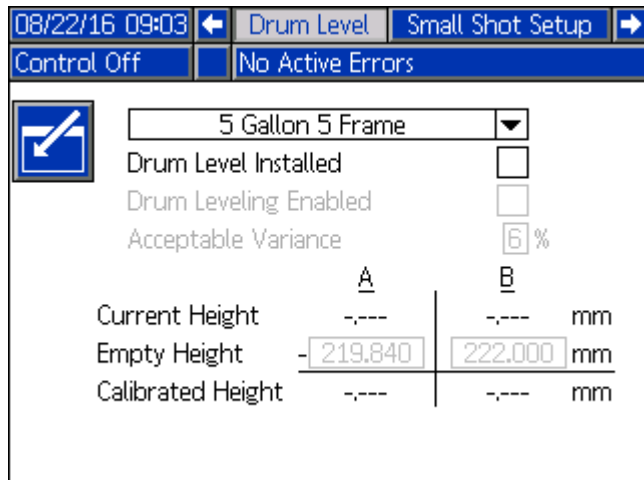

2. Press the  key to enter the screen to make changes.

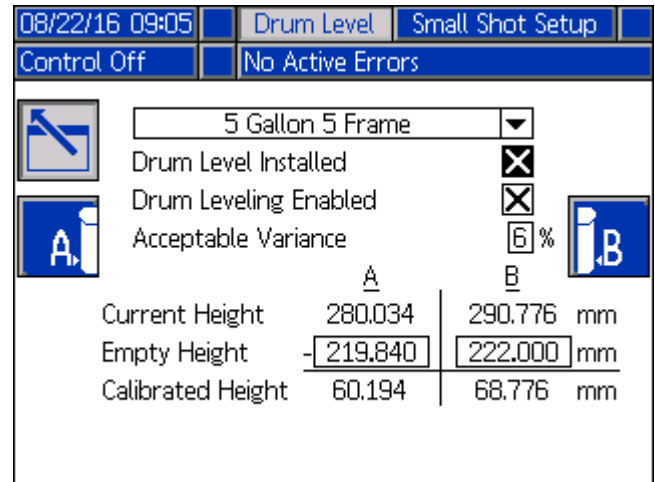

3. Select the Drum Level Installed check box to turn on this feature.
4. Select one of the three frame sizes from the drop down menu.
 - 55 gallon 55 frame
 - 5 gallon 55 frame
 - 5 gallon 5 frame
5. Lower the A side platen in the down position resting the platen on the base with the amount of down force typically used in normal operation.

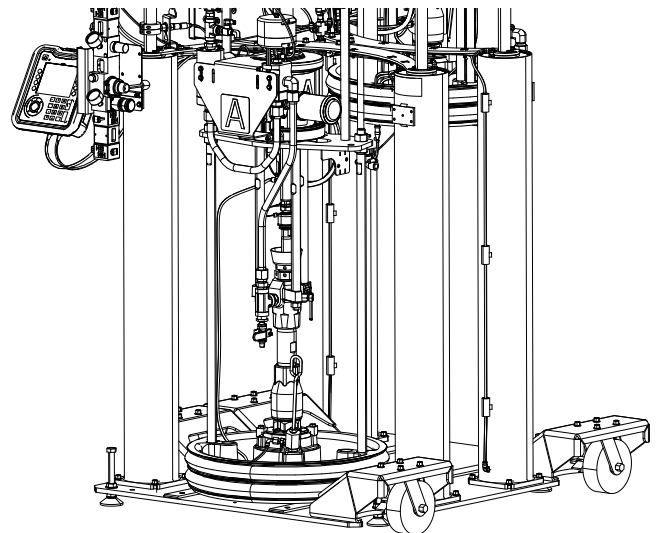

6. Calibrate the bottom by pressing the  key on the ADM. This changes the Empty Height value to match the Current Height value (within allowable variance).

The Calibrated Height is the difference of the Current Height minus the Empty Height and is calculated once this calibration is completed. The Calibrated Height will automatically change as the Current Height changes when the machine is being used.

NOTE: If the Empty Height is greater than the Current Height, “XX” appears in the Calibrated Height field.

7. Repeat steps 5 and 6 for the B side.

When the continuous level sensors are installed and calibrated, there are various ways to monitor the material in the drums. See **Home Screen Operation** on page 44 and **ADM Maintenance Screens** on page 47.

Acceptable Ratio Variance

When you select Drum Level Installed, the Drum Leveling Enabled check box is also selected. When this is active, you can have the system run at an acceptable ratio variance that helps to ensure that the A and B drums finish emptying material at the same time.

This is helpful if the drums are not filled at the same volume or more material has been purged from one side than the other.

The default value for the Acceptable Variance is 6%. It can be set as low as 0% and as high as 9%.

NOTE: If the Acceptable Variance is set too low, the A and B material drums may not finish emptying at the same time.

NOTE: The F4 machines can be set to use a variable ratio at the Material Setup screen. See **Set the Variable Ratio** on page 32.

Small Shot Mode

When running dispense cycles that are less than 5 grams, it is recommended that you use small shot mode on the F4 Series system to effectively maintain material mix and ratio accuracy.

There are several system requirements for running in small shot mode:

- The F4 Series machine must use a barrel mixing stack. The system has to control the A and B valves at the stack.
- A material regulator must be used with the barrel mixing stack.
- The Small shot Kit for LSR (part no. 25C237) is required. The kit includes a custom software blue token that must be inserted into FCM2 to enable this feature.

Refer to the F4 Series Kits-Accessories manual for information about the pressure transducer kit and the stacks and regulators that can be used with the pressure transducer. Refer to Related Manuals on page 3.

Small Shot Operation





The material regulator is used to regulate the outbound pressure of mixed material to the press and is able to handle pressure fluctuations on the inbound side. Ideally the inbound pressure should be a minimum of 600 psi above the outbound pressure to ensure constant pressure on the material regulator.

When the F4 system is running in small shot mode, the pressure on the inbound side of the material regulator is managed by using the Low Setpoint and the Fill Above Setpoint values at the Small Shot Setup screen in the ADM software. See Small Shot Setup on this page.

Pressure transducers installed at the A and B shutoff valves on the barrel mixing stack monitor the A and B pressure of the system up to the stack. When the pressure drops below the Low Setpoint value, the system dispenses material up to the Fill Above Setpoint value.

For example, if the Low Setpoint is set at 1200 psi and the Fill Above Setpoint value is set at 600 psi, the system dispenses material when the pressure drops below 1200 psi and stops dispensing when the pressure reaches 1800 psi. If a material regulator is running at 400 psi to the press (outbound), this ensures that the inbound pressure stays more than 600 psi above the outbound pressure.

Small Shot Setup

1. Ensure the custom software blue token is inserted into FCM2.
2. On the ADM, press  to access the Setup screens. Use the right or left arrow key to navigate to the Small Shot Setup screen in the Menu Bar.
3. Press the  key to enter the screen to make changes.
4. Use the directional keypad to navigate to the item to be changed.
5. Use the numeric keypad to enter new values.
6. Press  to accept a new value or selection.
7. When you are finished making changes, exit the screen using the  key.

08/22/16 09:00	←	Small Shot Setup	Advanced	→
Control Off		No Active Errors		
				
	Low Setpoint	<input type="text" value="1200"/>	psi	
	Fill Above Setpoint	<input type="text" value="600"/>	psi	
	Dispense Timeout	<input type="text" value="300"/>	Sec	
	Delta PSI Advisory	<input type="text" value="50"/>	psi	
	Enable Small Shot	<input checked="" type="checkbox"/>		

Low Setpoint is the pressure threshold that the system must fall below before it starts dispensing material. The value can be set between 1200 and 1800 psi.

Fill Above Setpoint is the amount of pressure that the system adds above the Low Setpoint pressure when dispensing material. This pressure, which is stored in the hoses and stack, is used to bleed down the system while running small shots. This allows the F4 system to fill a larger volume of material to ensure the system stays on ratio. This can be set between 400 and 1200 psi.

Dispense Timeout is used to signal an alarm if the system cannot reach the controlled pressure in a specified amount of time. This value can be set between 40 and 300 seconds. See **Appendix B - ADM Error and Event Codes** on page 60 for solutions if an alarm is triggered.

Delta PSI Advisory allows you to set a pressure differential value between the A and B pressure readings. The system monitors the pressure of the A and B material as it is being dispensed. When the pressure reaches the Low Setpoint, the pressure readings for both A and B should be within the differential value set here. This can be set between 50 and 500 psi. See **Appendix B - ADM Error and Event Codes** on page 60 for solutions if an advisory is triggered.

Enable Small Shot - Select this box to run small shot mode. When selected, the pressure control configured at this screen is the primary driver of when the F4 system dispenses material.

NOTE: When Enable Small Shot is selected, the A and B pressure values are displayed on the ADM's home screen. This also enables the C and D pressure display. C and D values show as zero unless pressure transducers have been installed to monitor the pressure elsewhere in the system. The C and D values are only for monitoring. The A and B values control the system dispense.







NOTE: You need to make sure the custom software blue token is inserted into FCM2. If you attempt to enable small shot mode and the token is not in FCM2, an alarm is triggered and the F4 machine immediately shuts down.

NOTE: For information about changing the pressure units that are displayed in small shot mode, see **Change Pressure Units** on page 33.

Advanced Settings

At the setup screens, use the right or left arrow key to navigate to the Advanced screens in the Menu Bar.

Advanced Screen 1

- To make changes at this screen, press the  key to enter the screen.
- Use the directional keypad to navigate to the item to be changed.
- For numeric entries**, use the numeric keypad to enter the new value.
For non-numeric settings, press  then use the up arrow () and the down arrow () to change the selection.
- Press  to accept the new value or selection and exit editing mode using the  key.

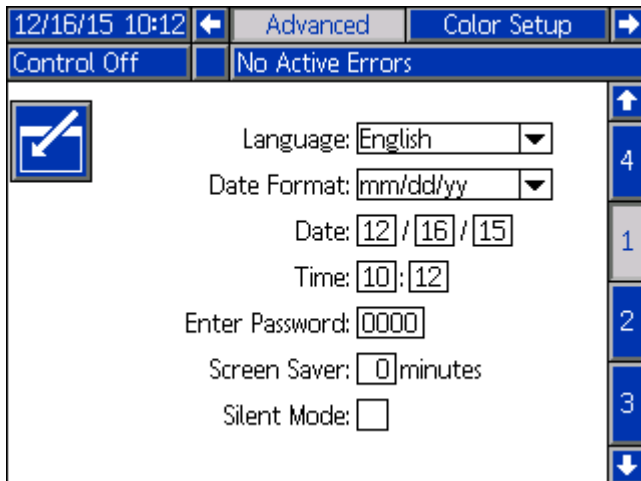

12/16/15 10:12 | Advanced | Color Setup

Control Off | No Active Errors



Language: English

Date Format: mm/dd/yy

Date: 12 / 16 / 15

Time: 10 : 12

Enter Password: 0000

Screen Saver: 0 minutes

Silent Mode:

1 2 3 4

Language

The Language selection feature allows you to change the language of all text on the display module. Available languages are English, Spanish, French, German, Chinese Simplified, Chinese Traditional, Japanese, Korean, and Italian.

Date Format

There are three available date formats to choose from: MM/DD/YY, DD/MM/YY, and YY/MM/DD.

Current Date and Time

Enter numeric values for the month, day, two-digit year, hour (24-hour clock), and minutes.

Password

If a password other than "0" is entered, the password is automatically enabled. The password protects entry into the Setup screens.

Screen Saver

The screen saver turns off the screen back-lighting after the number of minutes entered here. Enter 0 to leave it constantly on. To disable the screen saver, press any key.

Silent Mode

Check this box to turn off the buzzer for key presses on the ADM.

Advanced Screen 2

NOTE: See **Appendix C - USB Operation** on page 68 for additional information about USB logs.

- Use the up and down arrow keys to navigate to Advanced screen 2.
- Press the  key to enter the Advanced screen to make changes.

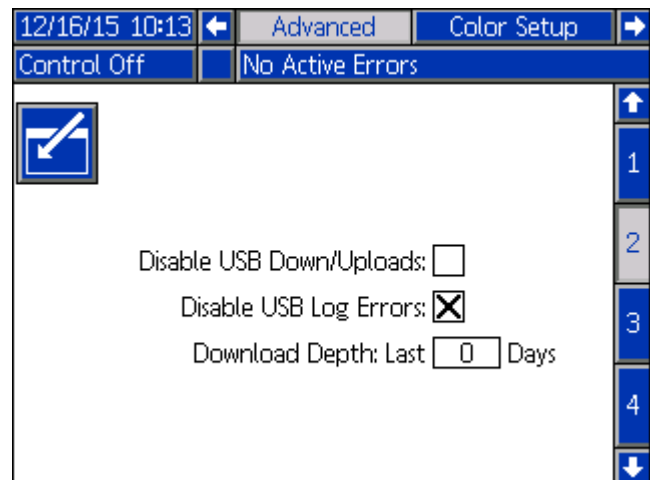

12/16/15 10:13 | Advanced | Color Setup

Control Off | No Active Errors



Disable USB Down/Uploads:

Disable USB Log Errors:

Download Depth: Last 0 Days

1 2 3 4

The first option is a check box that enables or disables the downloading of the error, event, and stack data log files.

Selecting Disable USB Log Errors eliminates the creation of the USB log error file during a download. This can reduce the amount of time involved in a download.



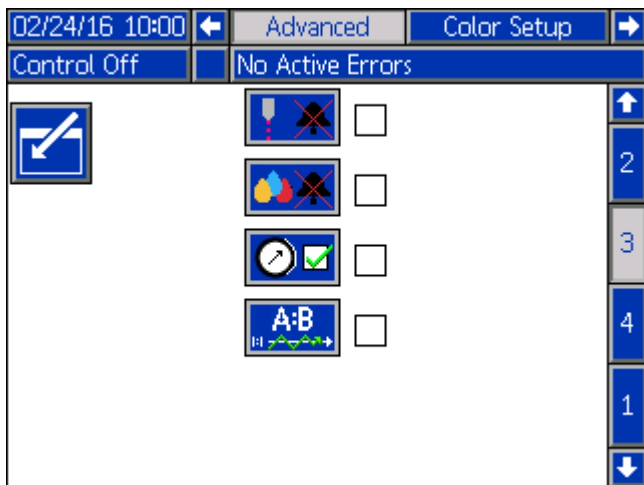

Download Depth enables you to select how many days in the past you want to have included in the download.

Advanced Screen 3

1. Use the up and down arrow keys to navigate to Advanced screen #3.
2. Press the  key to enter the Advanced screen to make changes.



There are four selections on this screen.

	Select to disable all firing frequency alarms for the color injector. See page 56 in Troubleshooting for information about firing frequency alarms.
	Select to disable all color alarms. See Troubleshooting , starting on page 56.
	Can be selected to display pressure values on the home screen if pressure transducers are installed.
	Select to enable strict ratio mode.

By default, strict ratio mode is off. When the system is operating in Control On mode (see **ADM Control Modes** on page 12), it evaluates the ratio of each previous shot. If the system detects a slight tolerance difference, it corrects the difference on the next shot. For example, if the previous shot had a ratio of 0.99, the next shot targets a ratio of 1.01.

The purpose of this is to ensure that there is not an imbalance in the drums as material is consumed.

Enabling strict ratio mode ignores past shot history. If you use strict ratio mode, the material may not be consumed equally and one drum may empty faster than the other.

NOTE: When drum-leveling is enabled, strict ratio mode is ignored. The drum-leveling mode has priority and adjusts the ratio to the acceptable ratio variance based on the measured drum levels. See **Acceptable Ratio Variance** on page 38.

NOTE: It is only necessary to select to display the pressure values on the home screen if you are not running small shot mode and if pressure transducers are connected to the system to monitor pressure. If the system is running in small shot mode, selecting Enable Small Shot selection at the Small Shot Setup screen displays the A and B as well as the C and D pressure values. See **Small Shot Mode** on page 38.

Advanced Screen 4

Use the up or down arrow keys to navigate to Advanced screen 4.

No changes can be made on this screen, but you can view the part numbers and current software versions.

02/24/16 09:58		Advanced	Color Setup	
Control Off		No Active Errors		
Module	Software Part #	Software Version		
Advanced Display	17C699	1.02.001		3
USB Configuration	17C702	1.01.005		4
FCM #1	17C703	1.02.001		1
FCM #2	17C704	1.02.001		2

Startup

						
To avoid pinching or amputation, do not operate the machine without all covers and shrouds in place.						

1. Turn the power on at the electrical enclosure.

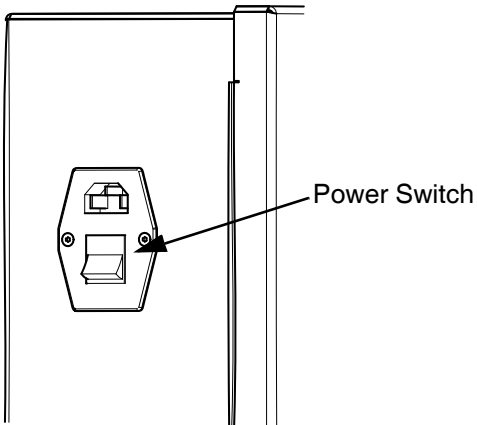

2. Turn on the system air slider valve on the main air control.

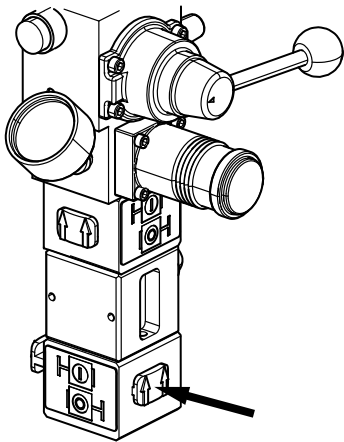

3. Turn on the main air slider valve.

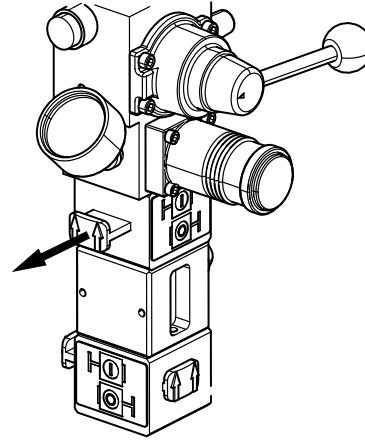

4. Turn on the secondary air slider valve.

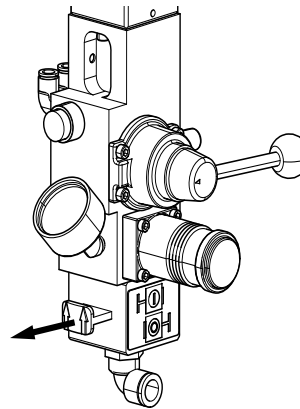

5. Turn on the air motor slider valves on both the main and secondary air controls.

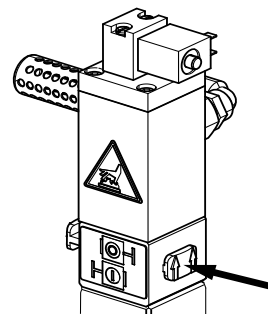

- Set the air motor regulator to the desired pressure.

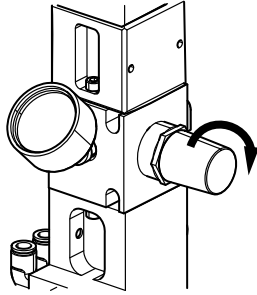

- Verify the ram director valves of the rams are set to lower the ram.

NOTE: To avoid pump cavitation, leave the ram director valves in the down position while pumping.

- The ADM starts at the Home screen in a safe mode (Machine Off) when power is first supplied to the machine.

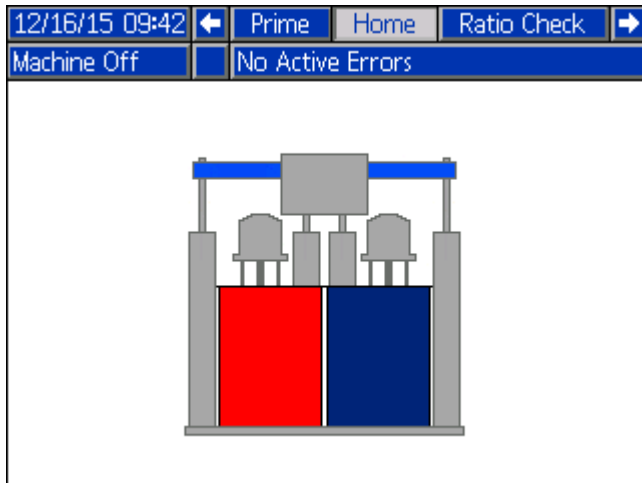

- Press  to enable Control Off on the Home screen.

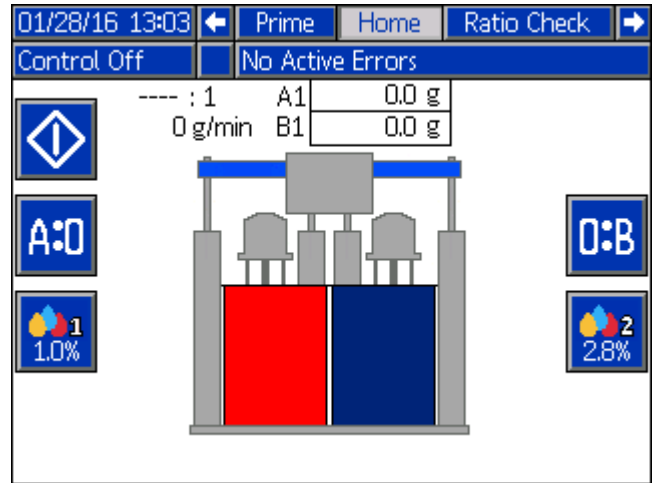

- Press the  key to enable Control On.

In Control On mode, the ratio and flow rates appear as in the screen below. A Go signal from the press is required to dispense any material from the Home screen. The ratio and flow rates update when the press activates the Go signal.

NOTE: A Go signal is required to dispense any material from the Home screen.

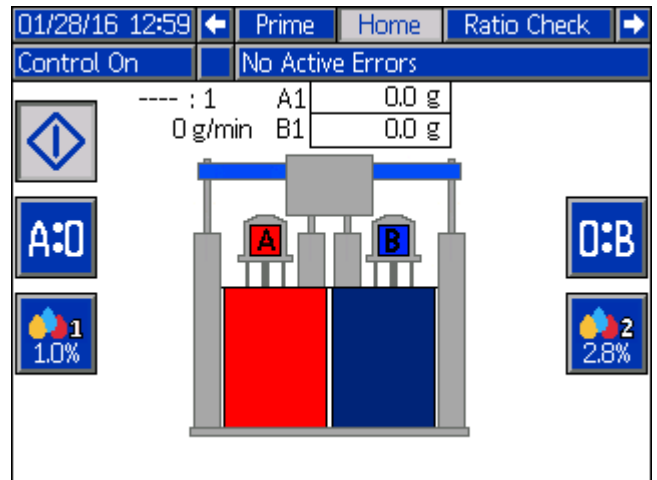



Operation

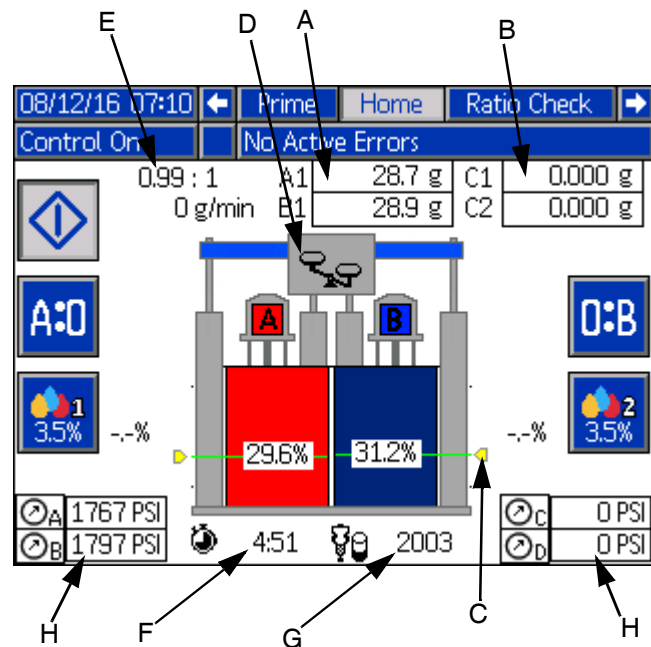

NOTE: Refer to the **ADM Screen Navigation Diagram** on page 14 to see the menu selections for the run screens described in this section.

Home Screen Operation

The  key on the Home screen is used to turn control on and off.



The  and  keys are used to purge material from A and B. See **Material Purge** on page 46 for information.

The  and  keys turn the color injector on and off. If color flow meters are installed, you need to perform the color learning process. See **Color Learning** on page 45.

The accumulated material weight counters (**A**) are located near the top of the screen. The A1 and B1 material counters show on the screen if the Go signal is activated from Press 1. If the Go signal is activated from Press 2, the A2 and B2 counters are shown. When active, the counters continue to accumulate with each dispense.

The color counters (**B**) also accumulate with each dispense. The color counters (C1 and C2) only show on the screen if color flow meters are being used and the Flow Meter Installed box is checked (enabled) on the Color Setup Screen. See **Calibrate the Color Injector and Flow Meter** on page 35.

NOTE: All material counters are reset to zero whenever the  key is pushed.

The amount of material remaining in each drum is shown as a percentage (**C**) on the drum images. The scales (**D**) above the drum images show which side is running off ratio. Below the A drum image at the bottom of the screen is the estimated time (**F**) remaining until the drums are empty. Below the B drum image is the estimated remaining shots (**G**) until the drums are empty. All of these show on the display only when the continuous level sensors are installed and programmed. See **Continuous Level Calibration** on page 37.

The ratio and flow rates (**E**) are displayed above and to the left of the scales.

The pressure indicators (**H**) are for monitoring pressure in the system. A Small Shot Kit for LSR (25C237) is required for this feature. The pressure can also be used to run small shots. See **Small Shot Mode** on page 38 for information.

See **Main Display Components** on page 12 for additional information about ADM's Home screen features.

Color Learning

Color learning operation only applies to systems using color flow meters. Refer to **Calibrate the Color Injector and Color Flow Meter** on page 35 for information about the color setup function discussed in this section.

Color Injector without the Flow Meter Option

When a flow meter is not being used, the Flow Meter Installed setting on the Color Setup screen must be unchecked. In this mode, the system uses the Colorant g/dose and the Injected % value on the Color Setup screen to determine how often the color injector fires. The system measures the amount of A and B material dispensed based on these two values and fires the color injector to meet the desired Injected %.

Color Injector with the Flow Meter Option

The color flow meter provides feedback to the system about the flow of the color material. This feedback is used to correct the Colorant g/dose value in response to varying system operating conditions. The system then uses the color learning process described here to quickly adapt to the proper Colorant g/dose value.

Color Learning Description

The system's color learning operation occurs after:

- Power cycling the system.
- Changing specific color settings such as the k-factor or target color percent.
- A color-related alarm.

During the color learning operation, the system learns the color injector's true output, which varies depending on system flow rate, system fluid operating pressure, and the A, B, and color material properties. After learning these conditions, the system adjusts the color control to meet the specified color percent target.

NOTE: During the color learning process, it is recommended that the mixed color material is purged from the press into an empty container and disposed of when the process is completed.

At the Home screen, in Control On mode, press the



key to turn on the color injector. Initiate the color learning operation by activating the appropriate press Go signal as selected at the Color Setup screen.

Accumulated Material Weight Counters

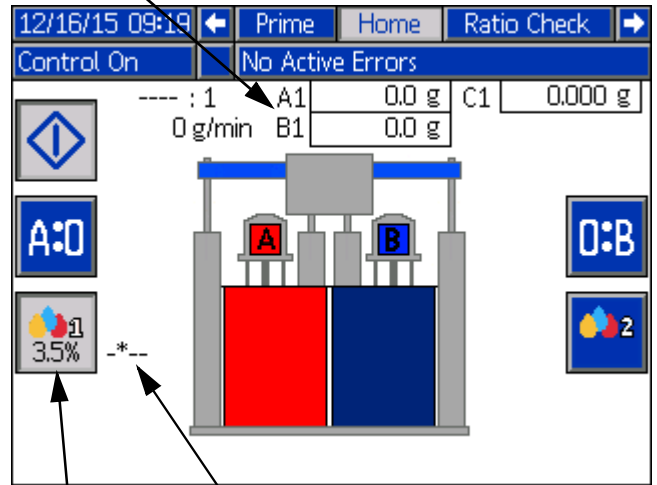

Color Setpoint Actual Color Percentage

In this example, the system would be targeting 3.5% for the color percentage. The progress shows in the actual color percentage field on the Home screen as follows.

*--	As material dispenses, the system is learning what percentage to run. The asterisk (*) slides back and forth from left to right until the system has learned the setpoint.
****	This shows that the system has learned its setpoint.
-.-%	This is displayed until a minimum of 30 total grams of material has passed through the A and B flow meters as shown at the accumulated material weight counters on the Home screen.
3.6%	After 30 grams of material has been dispensed, the actual color percentage should appear. The percentage value may continue to vary slightly within the tolerance of the settings, but should stabilize with continuous use.

NOTE: If the percentage has not stabilized within the color setting range by the time the machine has dispensed 50 grams of materials, an alarm is triggered.

If you are using a second color injector, the same procedure can be followed for the second color injector using

the key.

Ratio Check

NOTICE

An empty container should always be placed under the ratio check valve opening before using it to keep the material from dispensing onto the machine.

NOTE: The F4 machines can be set to use a variable ratio. See **Set the Variable Ratio** on page 32.

Perform the ratio check procedure to verify the ratio of the machine.

NOTE: All air must be purged from the machine (pump, dosing valves, flow meter, and hoses) to ensure accurate ratio checks. Trapped air in the system may give inaccurate results. See **Prime the Pumps** on page 26.

1. From the Home screen, use the right or left arrow key to navigate to the Ratio Check screen in the Menu Bar.
2. Close the material outlet valves to the stack on both the A and B sides.
3. Tare two empty containers on separate scales and then place a tared container under each of the ratio check ball valves.
4. Open both of the ratio check ball valves.

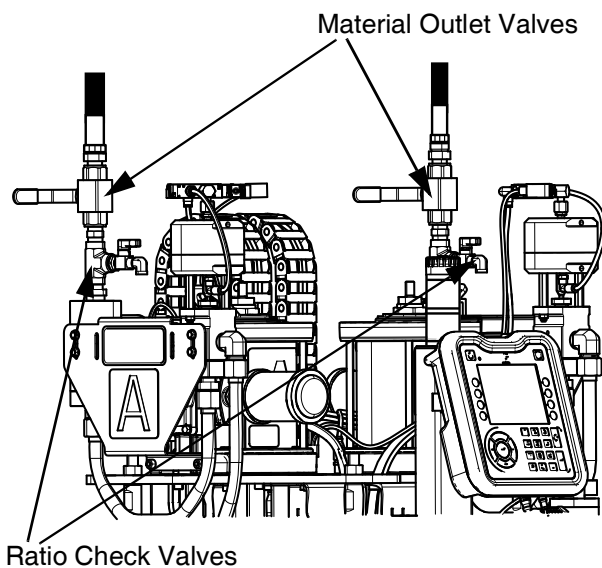

5. Press the **A:B** key to perform the ratio check. The dosing valve opens and closes automatically, dispensing material into the empty containers. A progress bar shows the status of the ratio check sequence.

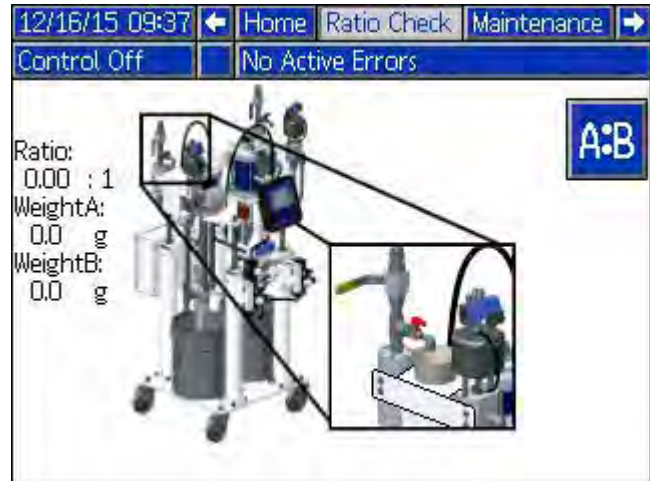

6. The system stops automatically when dispensing is completed. Close the A and B ratio check ball valves.
7. Weigh the material that was dispensed into the tared containers and divide A by B to check the ratio.
8. If the ratio is acceptable, you can return to the Home screen.

NOTE: A minimum of three ratio checks is recommended.



9. If the ratio is unacceptable, see page 57 in **Troubleshooting**.

Material Purge

Either the A or B material can be purged through the stack. Purging prevents mixed material in the stack's static mixer from curing. The machine remains pressurized and electrically connected.

NOTE: Refer to the material supplier to determine which material is best suited for purging. Normally, the supplier recommends using the B material to fill the mixer.

1. On the ADM, use the right or left arrow key to navigate to the Home screen in the Menu Bar.

2. Press either the  or  keys depending on which material you want to purge.
3. Activate the screw rotate (Go) signal on the press to start purging material through the stack's static mixer. Pump enough to purge the static mixer.

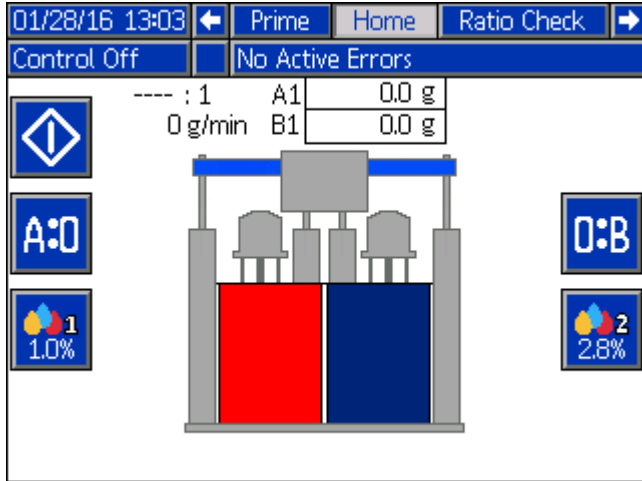

ADM Maintenance Screens

The ADM Maintenance screen 1 provides historical information for the two pumps in the system. This screen allows you to monitor how much material and color material is used for the life of the machine or for a period of time with the use of resettable counters.

1. Use the right or left arrow key to navigate to the Maintenance screen in the Menu Bar.

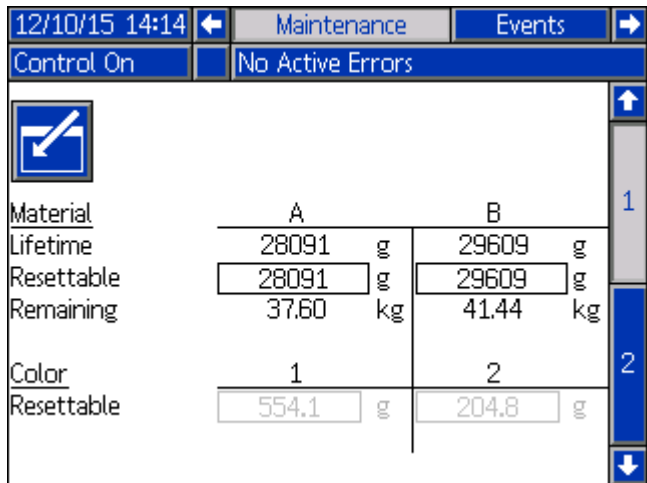



2. Press the  key to enter the Maintenance screen to make changes.

The Lifetime counters show the total amount of material in grams or kilograms (depending on the Mass Unit selection at the Material Setup screen) used by the A and B pumps machine since startup. These counters cannot be reset.

The other counters under Material and Color can be reset as needed. The Remaining material for both A and B is only shown when the continuous level sensor option is installed. See **Continuous Level Calibration** on page 37.

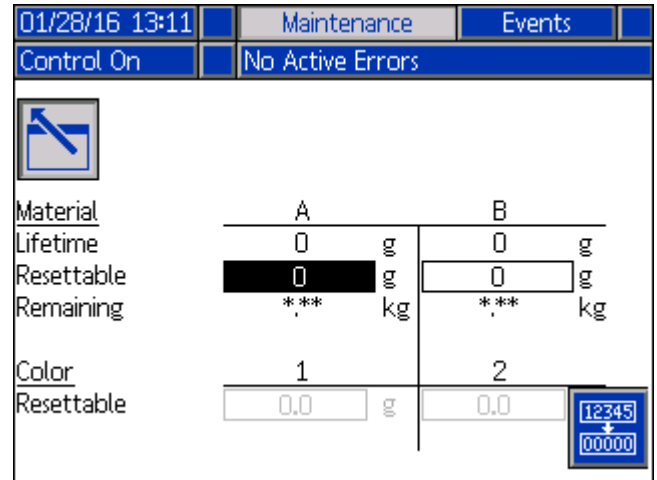
3. When you select a Resettable counter, a reset icon appears in the lower right corner of the screen.



4. Press the  key to reset the value to 0 (zero).
5. Repeat for any other counters you want to change.
6. Press the  key to exit the Maintenance screen when you have completed making changes.

You can return to the Maintenance screen at any time to monitor the progress or reset the counters.

On Maintenance screen 2, the pump performance can be evaluated for the A and B pumps. The amount of material (in grams) that has been dispensed for each pump is shown for the most recent five strokes. This can be used to help diagnose the performance of the pumps.

12/16/15 10:01		Maintenance		Events	
Control On		No Active Errors			
PUMP STROKE	A		B		
1	45	g	50	g	
2	50	g	43	g	
3	45	g	49	g	
4	52	g	42	g	
5	43	g	48	g	

ADM Error Log

Use the right or left arrow key to navigate to the Errors screen in the Menu Bar.

This screen shows a list of the 100 most recent errors that occurred in the system. Each error entry includes a description and error code along with a date and time stamp. See **Appendix B - ADM Error and Event Codes** on page 60 for a description of the error codes.

06/16/15 15:18		Events		Errors		Diagnostic		Prime	
Control Off		No Active Errors							
Date	Time	Code	Description						
06/16/15	15:14	CACD	FCM 1 Missing						

ADM Event Log

Use the right or left arrow key to navigate to the Events screen in the Menu Bar.

The Events screen shows a list of the 100 most recent events that occurred in the system. Each event includes a description and event code along with a date and time stamp. See page 67 in **Appendix B - ADM Error and Event Codes** for a description of the event codes.

06/16/15 15:15		Maintenance		Events		Errors	
Control Off		No Active Errors					
Date	Time	Code	Description				
06/16/15	15:07	EQUJ	USB Disk Removed				
06/16/15	15:07	EQUJ	USB Settings Download				
06/16/15	15:07	EQUF	USB Custom Language Download				
06/16/15	15:07	EQUJ	USB Logs Downloaded				
06/16/15	15:07	EQU9	USB Activity In Process				
06/16/15	15:07	EQUB	USB Drive Inserted				
06/16/15	15:04	EQUJ	USB Disk Removed				
06/16/15	15:03	EQUE	USB Settings Upload				
06/16/15	15:03	EQUJ	USB Settings Download				
06/16/15	15:03	EQUF	USB Custom Language Download				

ADM Diagnostics

The Diagnostic screen on the ADM can aid in troubleshooting by showing the status of important F4 Series components.

Use the right or left arrow key to navigate to the Diagnostic screen in the Menu Bar.

12/16/15 10:04		Errors		Diagnostic		Prime		Home	
Control On		No Active Errors							
Output				Input					
A	B			A	B				
○	●	Material Valve		●	○	Air Motor Top Switch			
●	●	Stack 1 Valve		●	●	Flow Meter			
○	○	Stack 2 Valve		1	2				
●	●	Air Motor		●	○	Screw Rotate			
1	2			○	○	Color Flowmeter			
●	○	Color Dosing Valve		Misc					
●	○	Machine Ready		○					
○	○	Purge Ready		1558	mV	Drum Level A			
Misc				1724	mV	Drum Level B			
○		Machine Fault							

NOTE: Values are only displayed in Drum Level A and Drum Level B in you are using the continuous level sensors.

Refer to the following table for a description of the outputs and inputs and what the indicators mean for each.

Output	Indicator
Material Valve	Dosing valve status indicator. Green = open, White = closed.
Stack 1 Valve	Stack control valve solenoid status indicator. Green = open, White = closed.
Stack 2 Valve	Stack control valve solenoid status indicator. Green = open, White = closed.
Air Motor	Air motor solenoid status indicator. Green = open, White = closed.
Color Dosing Valve	Color injector status indicator. Green = open, White = closed.
Machine Ready	Relay board output status for press 1 and 2 ready signals. Green = ready, White = not ready.
Purge Ready	Relay board output status for press 1 and 2 purge ready signals. Green = ready, White = not ready.
Machine Fault	Fault output status indicator. Green = machine fault active, White = no machine fault active.
Input	Indicator
Air Motor Top Switch	Pump direction status indicator. Green = pump moving up, White = pump moving down.
Flow Meter	Flow indicator. Green = flow detected, White = no flow detected.
Screw Rotate	Screw rotate (Go) signal. Green = screw rotate signal detected, White = no screw rotate signal detected.
Color Flow Meter	Color flow indicator. Green = flow detected, White = no flow detected.

Drum Level Low	Drum low level indicator. Green = drum A or B low level detected, White = low level not detected.
Drum Level A	Actual value of continuous level sensor in millivolts (mV).
Drum Level B	

Prime Screen

Use the right or left arrow key to navigate to the Prime screen in the Menu Bar. This screen provides the controls to energize each pump's air motor to allow air and material to be purged from the pump for pump priming. See **Prime the Pumps** on page 26 for detailed information about this screen and the priming process.

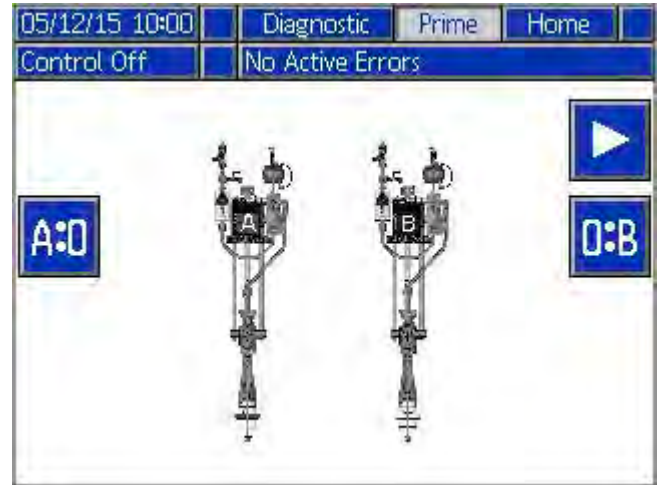

Shutdown

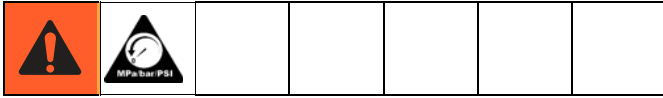

1. Perform the **Pressure Relief Procedure** as described below.
2. After you complete the procedure, turn the power off at the electrical enclosure.

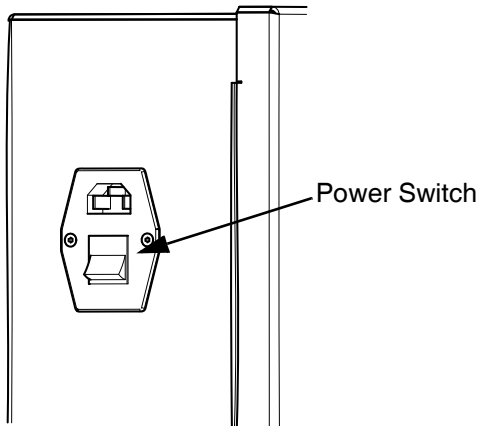

NOTE: There is pressure on each side of both the A and B dosing valves. Pressure must be relieved on the pump side and the stack side of the dosing valves.

1. To relieve pressure at the pump, turn off the system air slider valve.

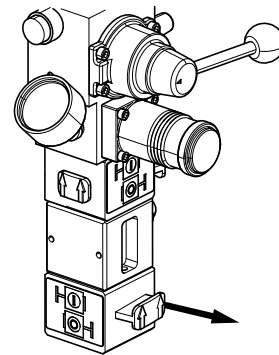

2. Open the prime ball valves for both the A and B pumps (turn the handle down).

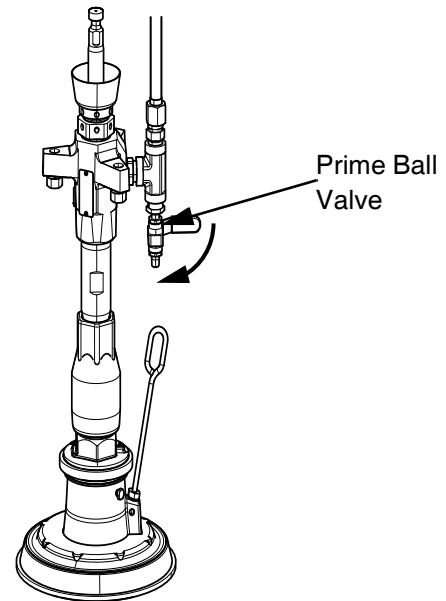

Pressure Relief Procedure



Follow the **Pressure Relief Procedure** whenever you see this symbol



This equipment stays pressurized until pressure is manually relieved. To help prevent serious injury from pressurized fluid, such as skin injection, splashing fluid and moving parts, follow the **Pressure Relief Procedure** when you stop dispensing and before cleaning, checking, or servicing the equipment.

NOTICE

Always place an empty container under the prime valves and the ratio check valves before using them to keep material from dispensing onto the machine.

3. To relieve pressure on the side leading out to the stack from the dosing valves, ensure the material outlet valves are open on the A and B side.

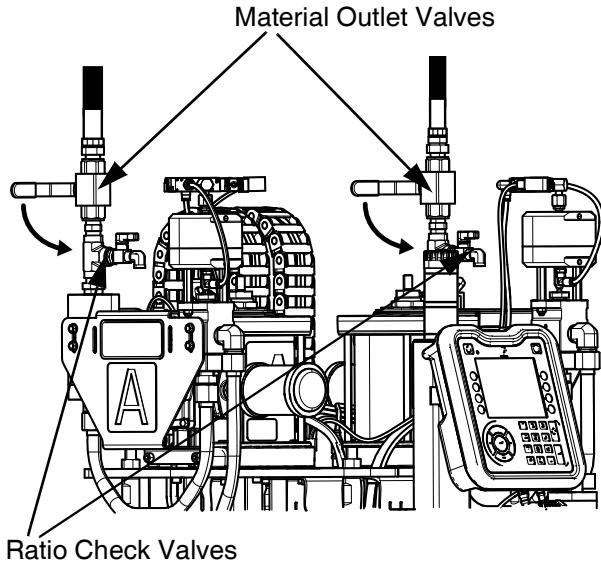

4. Open the ratio check valve on both the A and B side to relieve pressure.

NOTE: This procedure relieves air pressure from the entire system.

Maintenance



Where applicable, refer to the specific component manual for more detailed information about maintenance.

Task	Schedule
Check and tighten (as needed) throat seals on the pumps.	Weekly
Clean the stacks.	As Needed
Perform the shutdown procedure.	Daily
Adjust the packing nuts.	As Needed

Adjust Packing Nuts

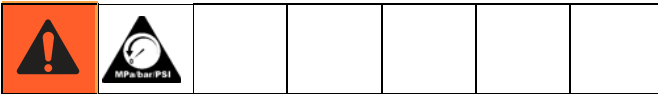

NOTE: There must be no pressure when adjusting the packing nuts. Any air pressure to the system is too much.

1. Follow the **Pressure Relief Procedure**, as described on page **50**, including relieving air pressure in the tanks.
2. Fill the metering pump packing nuts with Silicone Oil if needed (not supplied).
3. After the Silicone Oil is added, torque the metering pump packing nuts to 50 ft-lb (6.75 N•m). Follow instructions in the Dosing Valve Instructions, manual 313342.

4. If there is any material leakage, tighten the dosing valve packing nuts 1/4 turn after the nut contacts the packings; about 145-155 in-lb (16-18 N•m).

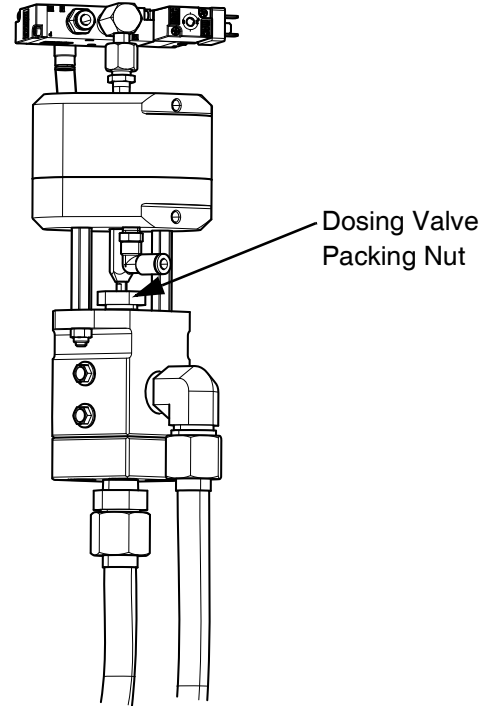

Seals

Once a week, check the throat seals on the pumps and tighten them as needed. See the Check-Mate® Displacement Pumps Instructions - Parts manual 312375 for more information.

ADM Battery Replacement and Screen Cleaning

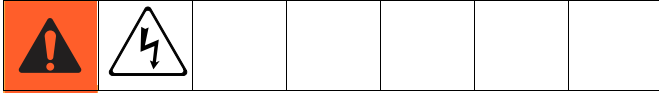

Battery Replacement

A lithium battery maintains the ADM clock when power is not connected.

To replace the battery:

1. Disconnect power to the ADM.

NOTE: This can be done by removing the CAN cable from the bottom of the ADM.

2. Use a hex key to remove the battery access panel.

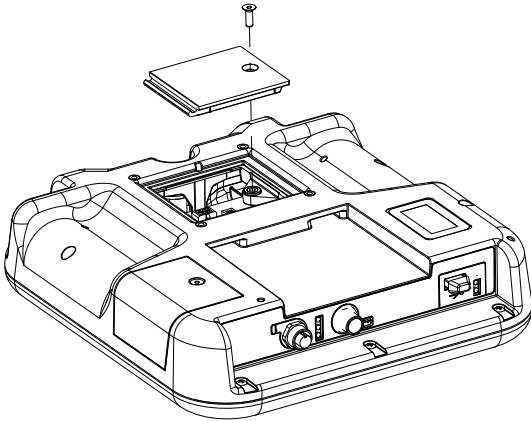

3. Remove the old battery and replace it with a new CR2032 battery.
4. Properly dispose of the old lithium battery according to local codes.
5. Replace the battery access panel.
6. Connect the power to the ADM and reset the clock.

Cleaning

Use any alcohol-based household cleaner, such as glass cleaner, to clean the ADM. Spray the cleaner on the rag, then wipe the ADM. Do not directly spray the ADM. Replaceable screen protectors, part number 15M483, are available.

Software Update Procedure

When software is updated on the ADM, the software is then automatically updated on all connected GCA components. A status screen is shown while the software is updating to indicate the progress.

1. Turn the power switch to OFF.
2. Remove the ADM from the bracket.
3. Use a hex key to remove the token access panel.

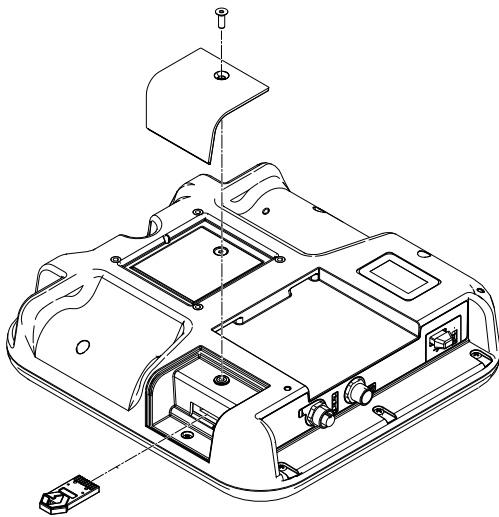

4. Insert and press the software upgrade token (Token part no. 17C706) firmly into the slot.
5. Turn the power switch to ON.

NOTICE

A status is shown while software is updating to indicate progress. To prevent corrupting the software load, do not remove the token until the status screen disappears.

6. The Graco splash screen (see page 24) is displayed until communication with other modules is established.
7. Select which software is applied to each module when multiple software options exist.

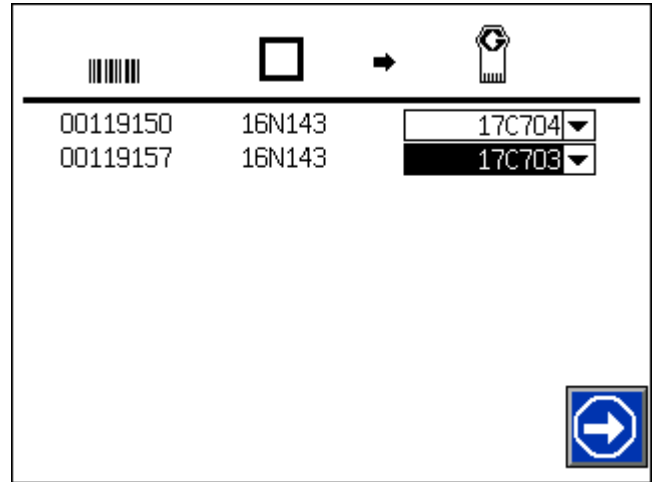

NOTE: Ensure that the correct software is selected for each Fluid Control Module (FCM). Do not install the software for FCM #1 into FCM #2 and vice versa.

8. Wait for the update to complete. An approximate time to completion displays below the progress bar.
9. When the software update is complete, one of the following icons will appear on the screen.

Icon	Description
	Update successful.
	Update unsuccessful.
	Update complete, no changes necessary
	Update was successful/complete but one or more GCA modules did not have a CAN boot-loader, so the software was not updated in that module.

10. When the update is completed successfully, remove the token.
11. Replace the token access panel.

12. Press to continue.

Troubleshooting



NOTE: Follow the **Pressure Relief Procedure** on page 50 before checking or repairing a dispense valve.

NOTE: Check all possible problems and causes before disassembling a dispense valve.

Mechanical and Electrical Troubleshooting

Pump		
Problem	Cause	Solution
The pump continues to move after the stack valves and dosing valves are closed.	Fluid is leaking.	Verify no external leakage is present.
		Verify the pump ball valve and bleed port are closed.
		Verify the ratio check ball valve is closed.
There is abnormal pump pressure during operation.	Malfunctioning seat/intake valve on the pump.	Clean or replace the seat/intake valve on the pump.
	Worn or damaged packings.	Replace the packings.
The pump will not dispense material.	Worn or damaged seat/intake valve on the pump.	Clean or replace the seat/intake valve on the pump.
	The air motor is not receiving compressed air or the air pressure is too low.	Verify that the pump air pressure is set above 20 psi.
The material drums are empty.		Verify that the air motor slider valves are open on both A and B air controls.
	The system displays pump run-away.	This error normally occurs when the pump cavitates due to improper loading of material.
Load new material in the drum.		
There is air entrapment in the pump.		Verify the ram director valve is in the down position.
		Verify that there is enough down force on the ram.
		Purge the air out of the pump through the pump ball valve.

Machine		
Problem	Cause	Solution
A material low level sensor advisory occurs unexpectedly or too early.	The shaft collar is not adjusted correctly.	Adjust the shaft collar.
	The cable or a metallic object is interfering with the sensor.	Ensure the sensor area is free of interfering objects.
Dosing Valve is leaking at the rod.	Loose or worn packings.	Tighten packing nut. If leak continues, replace the packings.
Dosing valve is leaking between main housing and outlet housing.	Bad o-ring on seat.	Replace both o-rings on the seat.
Dosing valve is not cycling.	Loose or bad cable.	Tighten or replace the cable.
	Bad solenoid valve.	Replace the solenoid valve.
	There is no air in the system.	Ensure there is sufficient air pressure to the system.
	There is no power to the system.	Ensure there is power to the system.
The machine will not dispense material.	No material supply to the system.	Verify there is sufficient down force on the ram (control lever should be in the down position).
		Verify that the A and B material outlet ball valves running from the machine to the stack are open.
	The drum/pail is empty.	Load new material.
	There is no air to the system.	Ensure there is air to the system.
	There is no power to the system.	Ensure there is power to the system.
	The machine is not receiving the screw rotate (Go) signal.	Ensure that the Go signal wiring is properly connected. See Connect the Electrical Signals to the Press on page 23.
Color firing frequency is high.	Percentage of color is set too high for flow rate.	Turn down the color percentage or decrease the flow rate.
	Color injector stroke length is not long enough to keep up with flow rate.	Increase the color injector stroke length and recalibrate color injector.
Color firing frequency is low.	Percentage of color is set too low for flow rate.	Increase the color percentage.
	Color injector stroke length is too long to inject at low percentage.	Decrease the color injector stroke length and recalibrate the color injector.
USB log is full.	The system will display this notification when the USB data logs reach 90% full.	To prevent data loss, download the system data. See Appendix C, USB Operation on page 68.

Machine		
Problem	Cause	Solution
ADM is not displaying when system is turned on.	The main power is turned off or the power cord is unplugged.	Turn power on or plug in the power cord.
	Cable or ADM unplugged.	Reconnect the ADM cable.
	Bad 24VDC power supply.	Check the output on the power supply, which should measure 24VDC. If there is no voltage reading, replace the power supply.
	Blown fuse at the on/off switch/EMI filter.	Replace the fuse(s).
	ADM is defective.	Replace the ADM.
Unacceptable ratio check.	Air entrapment.	Ensure the air is purged from the material lines. See Prime the Pumps on page 26.
	Bad flow meter.	Replace the flow meter.
	Improper flow meter calibration.	Check the flow meter K-Factor.
		Recalibrate the flow meters. See Calibrate the Flow Meter on page 30.
Small shot mode timeout	There is a leak in the system keeping it from reaching the set pressure.	Verify that no external leak is present. Repair the leak if one is found.
	The air motor pressure regulator is not high enough to reach the set pressure.	Increase the air motor pressure.

Stack		
Problem	Cause	Solution
Stack valves are not cycling.	There is no air supply to the stack.	Verify air is connected to the stack.
		Verify air is turned on to the stack.
	Bad cable.	Replace the cable.
	Cable not connected to the stack valve solenoid.	Verify the cables are connected to the stack.
	The solenoid is locked.	Unlock the solenoid.
	Bad stack valve solenoid.	Replace stack valve solenoid.
No power.	Verify the power is supplied to the machine.	

Stack		
Problem	Cause	Solution
The stack will not dispense material.	Stack valves are not opening.	Verify air is connected to the stack.
		Verify the cables are connected to the stack valve solenoid.
	Clogged/cured filter pack.	Clean or replace the filter pack.
	No pressure at the stack.	Verify the machine is running correctly. See Machine Troubleshooting on page 54.
	Clogged/cured static mixer.	Clean or replace the static mixer.
	Clogged/cured pressure regulator.	Clean or replace the pressure regulator.
Color injector is not firing.	The cable is not connected to the color injector valve solenoid.	Verify the cable is connected to the color injector valve solenoid as well as to the electrical control box.
	Color injector is not turned on.	Verify that color 1 or 2 is turned on at the ADM Home screen.
	Solenoid valve manual actuator is locked.	Unlock the manual actuator.
	The wrong stack is selected in Color Setup.	Ensure the proper stack is selected.
	There is no air in the stack.	Ensure there is sufficient air pressure to the stack.
	There is no power to the stack.	Ensure there is power to the stack.
Color injector is not loading material.	The ball valve on the color tank is closed.	Open the ball valve at the color tank.
	The color tank is out of material.	Verify the material level in the color tank.
	There is trapped air in the color material fluid hose / color injector.	Open the bleed port on the color injector and see Prime the Color Injector on page 34.
	There is insufficient air pressure to load the material.	Increase the air pressure on the color tank as needed.
	The color platen is sunk in the color tank.	Remove the color platen.
	The color flow meter is clogged.	Clean or replace the color flow meter.

Appendix A - ADM Screen Icons

Icon	Description
	Enter Screen
	Exit Screen
	Control On/Off
	A Material Purge On/Off
	B Material Purge On/Off
	Color 1 Select/De-select
	Color 2 Select/De-Select
	Ratio Check
	Start Mode Sequence
	Start Mode Sequence
	Material A Flow Meter Calibration
	Material B Flow Meter Calibration
	Reset Material/Color Material Values
	Color Percent Error
	Color Injector Error, Improper Color Setup
	Check Color Flow Meter
	Material Low Level
	FCM #1 Missing

Icon	Description
	FCM #2 Missing
	Pump A Runaway
	Material A Flow Meter Error
	Pump B Runaway
	Material B Flow Meter Error
	Calibrate Drum Level A
	Calibrate Drum Level B
	Strict Ratio On
	Strict Ratio Off
	Pressure Sensor Enable
	Frequency Alarm Disable
	Color Alarm Disable

Appendix B - ADM Error and Event Codes

Error Codes

Error Code	Error Name	Error Type	Cause	Solution
CAC0-A	FCM1 Missing	Alarm	FCM 1 is unplugged from the CAN bus.	Verify the FCM CAN cable is plugged into the system.
			FCM 1 is damaged.	Replace the FCM.
			FCM 1 base is damaged.	Replace the FCM base.
			There is Improper software on FCM 1.	Update the software on FCM 1.
CAC1-A	FCM 2 Missing	Alarm	FCM 2 is unplugged from the CAN bus.	Verify the FCM CAN cable is plugged into the system.
			FCM 2 is damaged.	Replace the FCM.
			FCM 2 base is damaged.	Replace the FCM base.
			There is Improper software on FCM 2.	Update the software on FCM 2.
DAA5-A	Runaway on Pump A Detected	Alarm	Pump A is out of material.	The material drum is empty. Load new material as needed.
			The ram down force is not sufficient.	Verify the ram director valve is in the down position.
				Verify there is enough down force pressure on the ram.
There is air entrapment in the pump.	Purge air out of the pump through the prime ball valve.			
DAB5-A	Runaway on Pump B Detected	Alarm	Pump B is out of material.	The material drum is empty. Load new material as needed.
			The ram down force is not sufficient.	Verify the ram director valve is in the down position.
				Verify there is enough down force pressure on the ram.
There is air entrapment in the pump.	Purge air out of the pump through the prime ball valve.			

Error Code	Error Name	Error Type	Cause	Solution
F613-D	Color 1 Check Flow Meter	Deviation	The color flow meter 1 is not recording pulses.	Verify that the ball valve is open at the color tank.
				Verify that the flow meter cable is plugged in.
				Verify that the color tank has material.
				Verify that no air is trapped in the color injector. Bleed air as necessary at the color injector.
			There is insufficient air pressure on the color tank.	Increase the air as necessary.
F623-D	Color 2 Check Flow Meter	Deviation	Color flow meter 2 is not recording pulses.	Verify that the ball valve is open at the color tank.
				Verify that the flow meter cable is plugged in.
				Verify that the color tank has material.
				Verify that no air is trapped in the color injector. Bleed air as necessary at the color injector.
			There is Insufficient air pressure on color tank.	Increase the air as necessary.
F7A2-A	Unexpected Pulses Flow Meter A	Alarm	Flow meter pulses on the A side material have been recorded when there should not have been any.	Check hoses, tubing, and valves for leaks.
				Verify the ratio check ball valve is closed on the A side.
				Verify the A side dosing valve is closed and is not leaking past the ball and seat on the valve.
			There is a bad dosing valve solenoid valve.	Replace the solenoid valve.
			The dosing valve solenoid cable is not plugged in or is not functioning.	Attach or replace the solenoid cable.

Error Code	Error Name	Error Type	Cause	Solution
F7B2-A	Unexpected Pulses Flow Meter B	Alarm	Flow meter pulses on B side material have been recorded when there should not have been any.	Check hoses, tubing, and valves for leaks.
				Verify the ratio check ball valve is closed on the B side.
				Verify the B side dosing valve is closed and is not leaking past the ball and seat on the valve.
			There is a bad dosing valve solenoid valve.	Replace the solenoid valve.
			The dosing valve solenoid cable is not plugged in or is not functioning.	Attach or replace the solenoid cable.
F8A2-A	Expected Pulses Flow Meter A	Alarm	Flow meter pulses on the A side material have not been recorded when they were expected.	Verify the material outlet ball valve from the machine to the stack is open on the A side.
				Verify the A side air motor slider valve is open.
				Verify the flow meter cable is connected.
				The flow rate is too low for the flow meter. Increase the flow rate.
F8B2-A	Expected Pulses Flow Meter B	Alarm	Flow meter pulses on the B side material have not been recorded when they were expected.	Verify the material outlet ball valve from the machine to the stack is open on the B side.
				Verify the B side air motor slider valve is open.
				Verify the flow meter cable is connected.
				The flow rate is too low for the flow meter. Increase the flow rate.
H215-D	Firing Frequency Low Color 1	Deviation	This is only monitored in a closed loop when the color flow meter is installed. Too much A and B material has flowed through the flow meters before the color injector fired.	Increase the color percentage.
				Decrease the color injector stroke length.
				Recalibrate the color injector. See Calibrate the Color Injector and Color Flow Meter on page 35.
H225-D	Firing Frequency Low Color 2	Deviation	This is only monitored in a closed loop when the color flow meter is installed. Too much A and B material has flowed through the flow meters before the color injector fired.	Increase the color percentage.
				Decrease the color injector stroke length.
				Recalibrate the color injector. See Calibrate the Color Injector and Color Flow Meter on page 35.

Error Code	Error Name	Error Type	Cause	Solution
H315-D	Firing Frequency High Color 1	Deviation	The color injector is firing more than twice per second.	Turn down the flow rate.
				Decrease the color percentage.
				In open loop, increase the color injector length and recalibrate the color injector.
				In closed loop (with flow meter), increase the color injector stroke length.
				Recalibrate the color injector. See Calibrate the Color Injector and Color Flow Meter on page 35.
H325-D	Firing Frequency High Color 2	Deviation	The color injector is firing more than twice per second.	Turn down the flow rate.
				Decrease the color percentage.
				In open loop, increase the color injector length and recalibrate the color injector.
				In closed loop (with flow meter), increase the color injector stroke length.
				Recalibrate the color injector. See Calibrate the Color Injector and Color Flow Meter on page 35.
H510-A	Color 1 Invalid Setup	Alarm	The percentage of color is set too low for the injector g/dose setting.	Increase the color percentage setting.
				Decrease the color injector stroke length and recalibrate the color injector.
				Recalibrate the color injector. See Calibrate the Color Injector and Color Flow Meter on page 35.
H520-A	Color 2 Invalid Setup	Alarm	The percentage of color is set too low for the injector g/dose setting.	Increase the color percentage setting.
				Decrease the color injector stroke length and recalibrate the color injector.
				Recalibrate the color injector. See Calibrate the Color Injector and Color Flow Meter on page 35.
DDAS-A DDBS-A	Pump Dive A or B	Alarm	The material is empty.	Change the material.

Error Code	Error Name	Error Type	Cause	Solution
L1A4-V	Drum Low Level Detected	Advisory	A low Level of material has been detected on either A or B.	Verify that the material in the drum is low. Load new material as needed.
				Reposition the shaft collar as necessary.
				Keep the sensor area free of metallic obstructions.
MMUX-V	USB Log Full	Advisory	The USB data log has reached 90% full.	To prevent data loss, download the system data. See Appendix C - USB Operation on page 68
P6A1	Unexpected Pressure Reading A	Alarm	Invalid pressure reading	Verify the pressure transducer is plugged into FCM2 at the correct port.
P6B1	Unexpected Pressure Reading B	Alarm		Verify the pressure transducer is functioning correctly. Replace if necessary.
P3FX	Max Pressure Differential	Advisory	Pressure between A and B is greater than the Delta PSI Advisory setting.	Verify that the pressure transducer is correct compared to a manual gauge. Replace if necessary.
				Verify that there are no leaks in the system.
				Verify that the A/B stacks valves are open. See Small Shot Mode on page 38.
P8FX	Small Shot Mode Timed-out	Alarm	System did not reach pressure is allotted time.	Increase the small shot mode timeout amount.
				Increase the air motor pressure.
				Decrease the Fill Above Setpoint value. See Small Shot Mode on page 38.
				Verify that there are no leaks in the system.

Error Code	Error Name	Error Type	Cause	Solution
R21X-D	Color 1 Percent Low	Deviation	A low limit allowable color deviation percentage has been detected on Color 1. This is only in closed loop color with the flow meter.	Verify that the color tank ball valve is open.
				Verify that the color flow meter cable is connected.
				Verify that there is no air trapped in the color injector. Bleed air as necessary at the color injector.
				Increase the deviation percentage.
				Recalibrate the color flow meter. See Calibrate the Color Injector and Color Flow Meter on page 35.
R22X-D	Color 2 Percent Low	Deviation	A low limit allowable color deviation percentage has been detected on Color 2. This is only in closed loop color with the flow meter.	Verify that the color tank ball valve is open.
				Verify that the color flow meter cable is connected.
				Verify that there is no air trapped in the color injector. Bleed air as necessary at the color injector.
				Increase the deviation percentage.
				Recalibrate the color flow meter. See Calibrate the Color Injector and Color Flow Meter on page 35.
R31X-D	Color 1 Percent High	Deviation	A high limit allowable color deviation has been detected on color 1. This is only in closed loop with the flow meter.	Increase the deviation percentage.
				Recalibrate the color flow meter. See Calibrate the Color Injector and Color Flow Meter on page 35.
R32X-D	Color 2 Percent High	Deviation	A high limit allowable color deviation has been detected on color 1. This is only in closed loop with the flow meter.	Increase the deviation percentage.
				Recalibrate the color flow meter. See Calibrate the Color Injector and Color Flow Meter on page 35.
WR01	Small Shot Requires Token	Alarm	Software blue token in FCM2 is not found.	Insert blue token into FCM2 if running small shot mode.
WSC2-A	Material K-Factor is Zero	Alarm	The K-factor for the material flow meter for A or B shows as zero.	Calibrate the flow meters for either A or B. See Calibrate the Flow Meter on page 30.

Error Code	Error Name	Error Type	Cause	Solution
WSC3-A	Color K-factor is Zero	Alarm	The K-factor for the color flow meter shows as zero.	Perform a color calibration. See Calibrate the Color Injector and Color Flow Meter on page 35.
WSUX-V	USB Configuration Missing	Advisory	A valid configurator cannot be found for the USB.	The system is not properly loaded with correct software. Update the software as described in the Software Update Procedure on page 54. Retry the USB download.
			The ADM is bad.	Replace the ADM.
WS13-V	Color 1 Unexpected K-Factor	Advisory	Color 1 flow meter is receiving improper pulses.	Verify that the color tank ball valve is open.
				Verify that the color flow meter cable is connected.
				Verify that the color material is in the tank.
				Verify that there is sufficient air pressure on the tank.
				Verify that there is no air trapped in the color injector.
				Clean or replace the color flow meter.
WS23-V	Color 2 Unexpected K-Factor	Advisory	Color 2 flow meter is receiving improper pulses.	Verify that the color tank ball valve is open.
				Verify that the color flow meter cable is connected.
				Verify that the color material is in the tank.
				Verify that there is sufficient air pressure on the tank.
				Verify that there is no air trapped in the color injector.
				Clean or replace the color flow meter.
L7AX-V L7BX-V	Level Sensor A or Level Sensor B Unexpected Value	Advisory	Drum level sensor metal draw wire is severed.	Replace sensor.
			Sensor not connected to bracket properly.	Properly mount sensor.
			Drum level sensor metal draw wire not attached to mounting bracket.	Properly mount draw wire to bracket.
			FCM2 I/O port is bad.	Replace FCM2.
			Obstruction in the path of the metal draw wire.	Remove obstruction.

Event Codes

Event Code	Event Name	Event Type	Description
ELMX-R	System Power On	Record Only	Power on event.
EMMX-R	System Power Off	Record Only	Power off event.
EQU9-V	USB Activity In Progress	Advisory	A USB download is in progress.
EQUB-R	USB Stick Inserted	Record Only	A USB stick has been inserted.
EQUC-R	USB Logs Downloaded	Record Only	USB logs have been downloaded.
EQUD-R	USB Settings Download	Record Only	Settings have been downloaded.
EQUE-R	USB Settings Upload	Record Only	Settings have been uploaded.
EQUF-R	USB Custom Language Downloaded	Record Only	A custom language has been downloaded.
EQUG-R	USB Custom Language Uploaded	Record Only	A custom language has been uploaded.
EQUH-R	USB Disk Idle	Record Only	The USB stick is idle.
EQUJ-R	USB Disk Removed	Record Only	The USB stick has been removed.

Appendix C - USB Operation



Overview

There are two main uses for the USB on a Fluid Automation F4 Series system.

- Ability to download a log of up to the past 188,244 errors, events, or jobs that can contain over 112,050 snapshots of critical dispense information.
- Ability to download, modify, and upload custom language files.

USB Options

The ADM option for the USB is on the Advanced screen 2.

1. On the ADM, press  to access the setup screens. Use the right or left arrow key to navigate to the Advanced screen in the Menu Bar.
2. Use the up and down arrow keys to navigate to Advanced screen 2.
3. Press the  key to enter the Advanced screen to make changes.

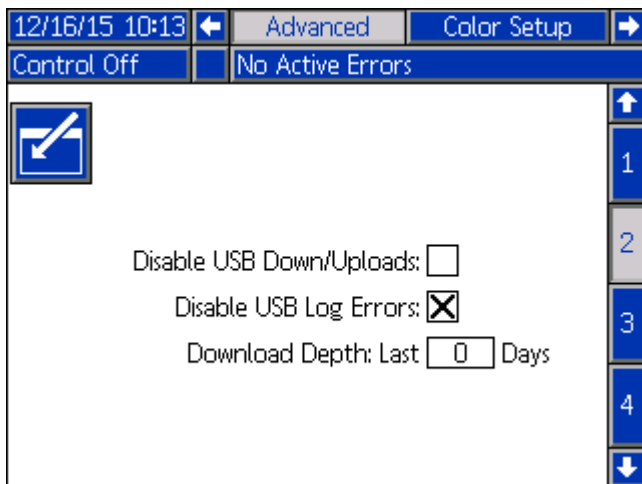

The first option is a check box that enables or disables the downloading of the error, event, and stack data log files. Stack data logs record the end of the shot data in the appropriate location.

USB Logs

During operation, system and performance related information is stored to memory in the form of log files. See **Download Files** on page 64 to retrieve the log files.

Event Log

The event log (1-EVENT.CSV) maintains a record of the last 188,244 events. Each event record in the log file contains the date and time the event occurred, the event type, event code, and event description.

GCA Log

This log (2-GCA.CSV) lists the installed GCA modules and their respective software versions.

Stack Log

The stack log (3-DATA.CSV and 4-DATA.CSV) tracks the material usage, color usage, and injected percentage setting for each shot of material, whichever is larger. Each log can store up to 112,050 lines of data.

Maintenance Log

The maintenance log (5-MAINTE.CSV) tracks total pump cycles, dosing valve cycles, stack valve cycles, color injector cycles, total material counter (grams), resettable material counter (grams), and resettable color counter (grams). This log can store up to 71,712 lines of data.

Change Log

The change log (6-CHANGE.CSV) tracks setpoint changes, logging the time, setting changed, and new value. This log can store up to 640 lines of data.

Prime Log

The prime log (7-PRIME.CSV) tracks material usage (grams) and machine mode (prime, purge, or ratio check). This log can store up to 188,244 lines of data.

Download Files

NOTE: The event log, error log, system settings, and system language files are all downloaded in this procedure.

1. Insert the USB stick drive into the port on the ADM. See **Software Update Procedure** on page 54 for the location of the USB port.

NOTE: The USB stick should be high-quality and must be 8 GB or smaller.

NOTICE

Low-quality USB stick drives may lead to burning out the USB port on the ADM. Use only high-quality USB stick-drives with the ADM USB port.

2. The menu bar and USB indicator lights show that the USB is downloading the files. Wait for the USB activity to finish. A progress status bar will show on the screen until the transfer is completed.

NOTE: The system can log up to 45 MB of additional data per week, depending on the system operation.

Access Files

All files downloaded onto the USB stick drive are in a DOWNLOAD folder. For example: "E:\GRACO\12345678\DOWNLOAD\." The 8-digit numeric folder name matches the 8-digit ADM serial number that is located on the back of the ADM.

When downloading from multiple ADMs, there will be one sub-folder in the GRACO folder for each ADM.

The folders and files should be uploaded to your computer for storage and future access under a Graco folder.

Open log files in a spreadsheet program.

Upload Files

This procedure is for uploading a system configuration file and/or a custom language file.

1. If necessary, follow the procedure for downloading files on this page to automatically generate the proper folder structure on the USB stick drive.
2. Insert a USB stick drive into a USB port on your computer.
3. The USB drive window should automatically open. If it does not, go to your computer's file management program and open it.
4. Open the Graco folder.
5. Open the system folder. If you are working with more than one system, there will be more than one sub-folder within the Graco folder. Each sub-folder is labeled with the corresponding serial number of the ADM.
6. If you are installing the system settings file, place SETTINGS.TXT file into the UPLOAD folder on the USB stick drive.
7. If you are installing the system language file, place DISPTXT.TXT file into the UPLOAD folder.
8. Remove the USB stick drive from the computer.
9. Install the USB stick drive into the appropriate ADM USB port.
10. The progress status bar and USB indicator lights indicate that the USB is uploading files. Wait for the USB activity to complete.
11. Remove the USB stick drive from the USB port.

NOTE: If the SETTINGS.TXT or DISPTXT.TXT files remain in the UPLOAD folder, they will be uploaded every time the USB stick drive is inserted into the corresponding ADM. To avoid unintentionally overwriting the system setting, delete the files from the UPLAOD folder on the USB drive after the upload is complete.

Appendix D - Color Limits

The following charts show color limits based on color injector settings. These charts should be used as a reference when you are determining the color injection percentage based on the system flow rate during the color injector calibration process. See **Calibrate the Color Injector and Color Flow Meter** on page 35

These charts are based on using a colored material with a 1.22 s.g. The flow rates are based on a 60 durometer material with a 1.12 s.g. and are intended as a starting point for setting up the color injector. Percentages and flow rates may vary based on material properties.

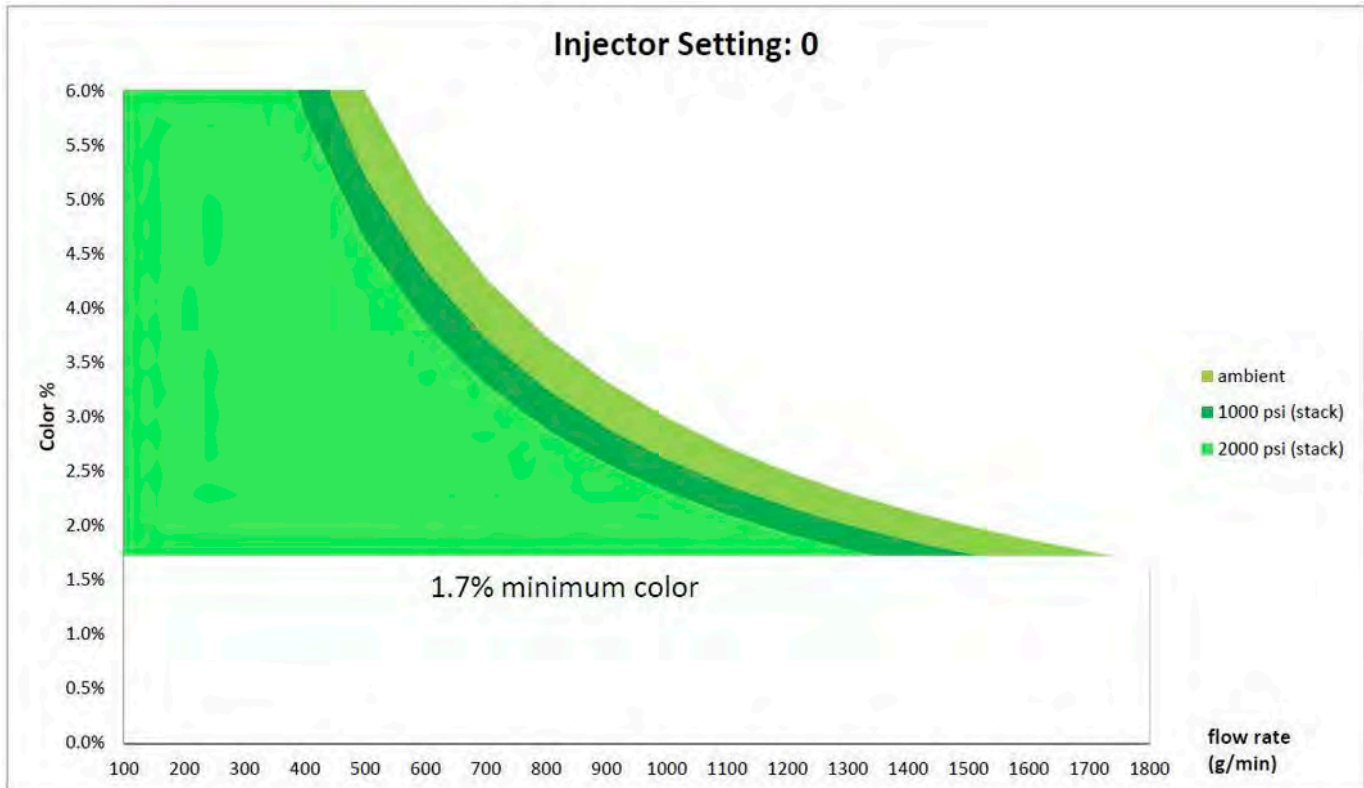

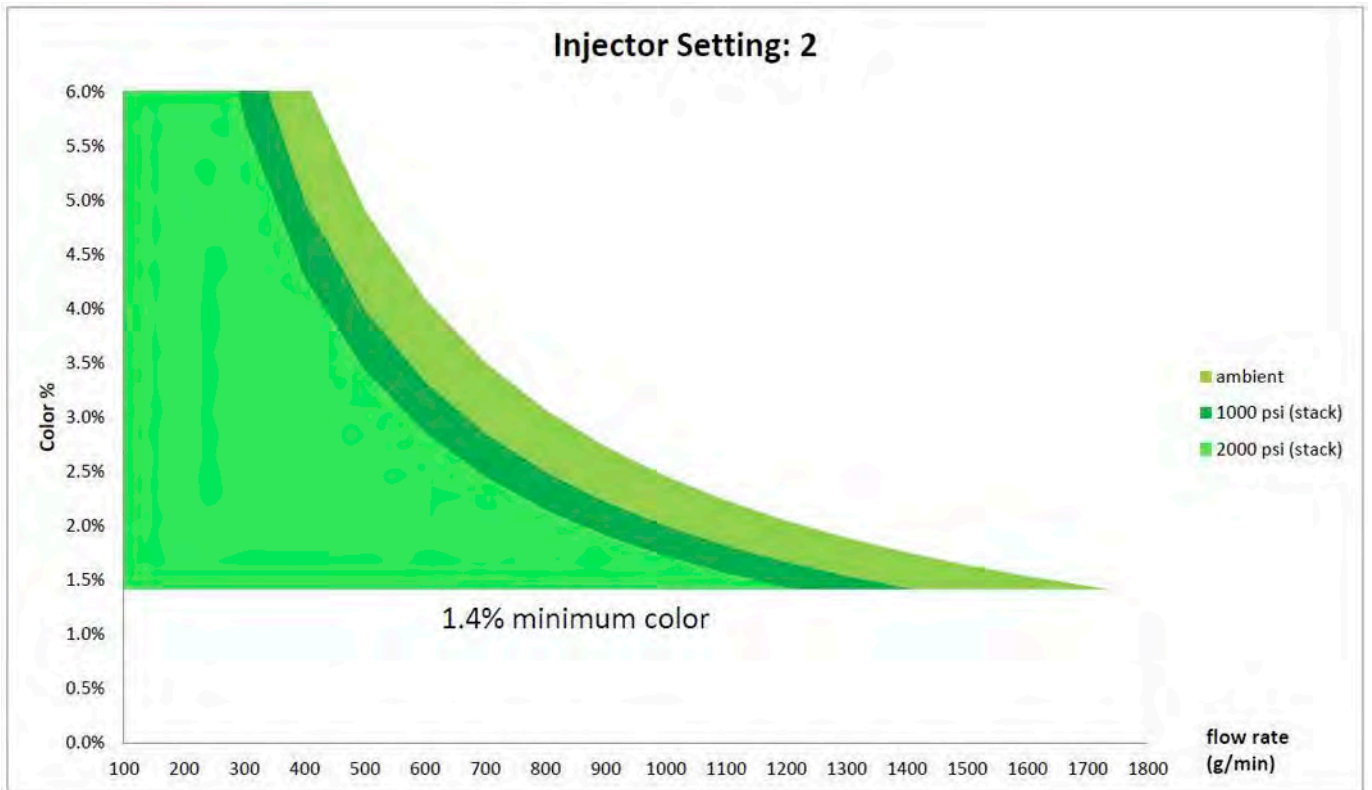
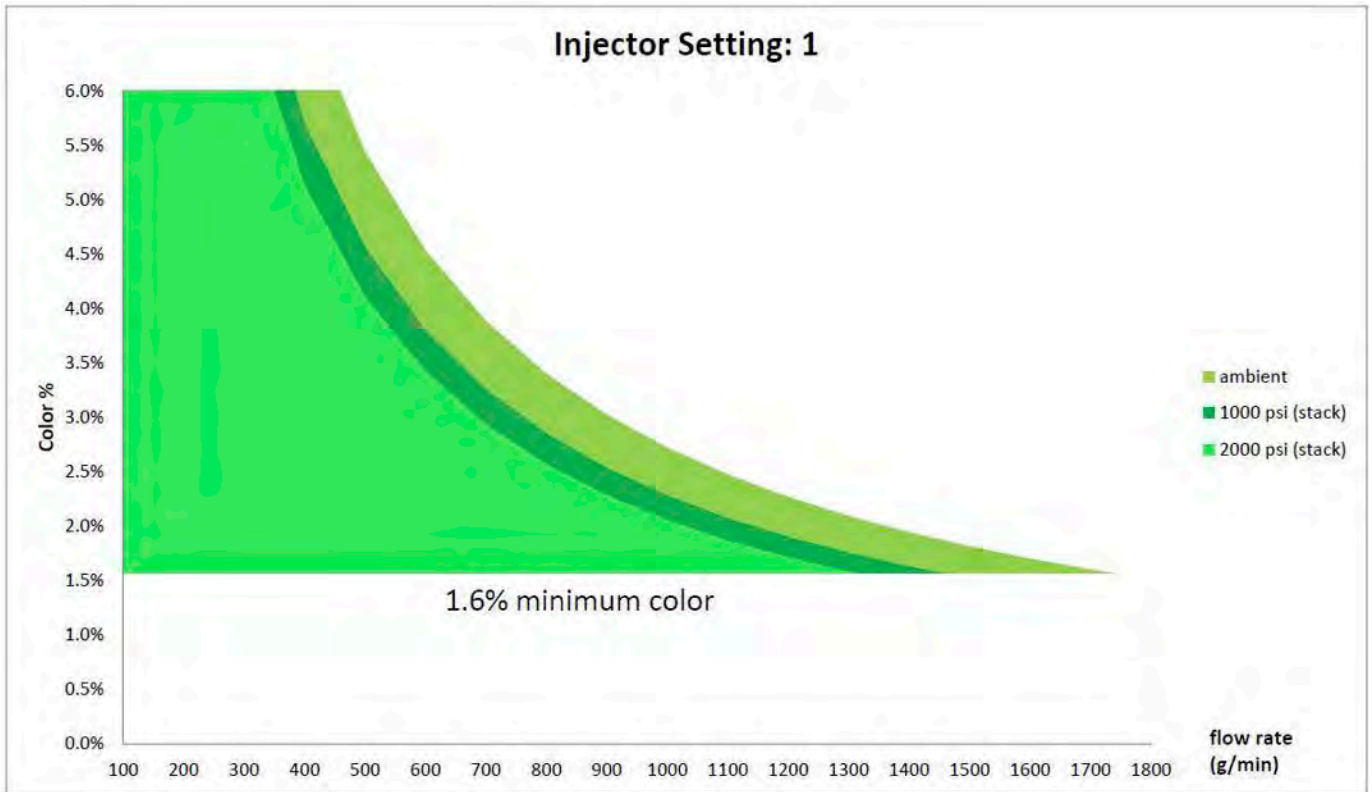

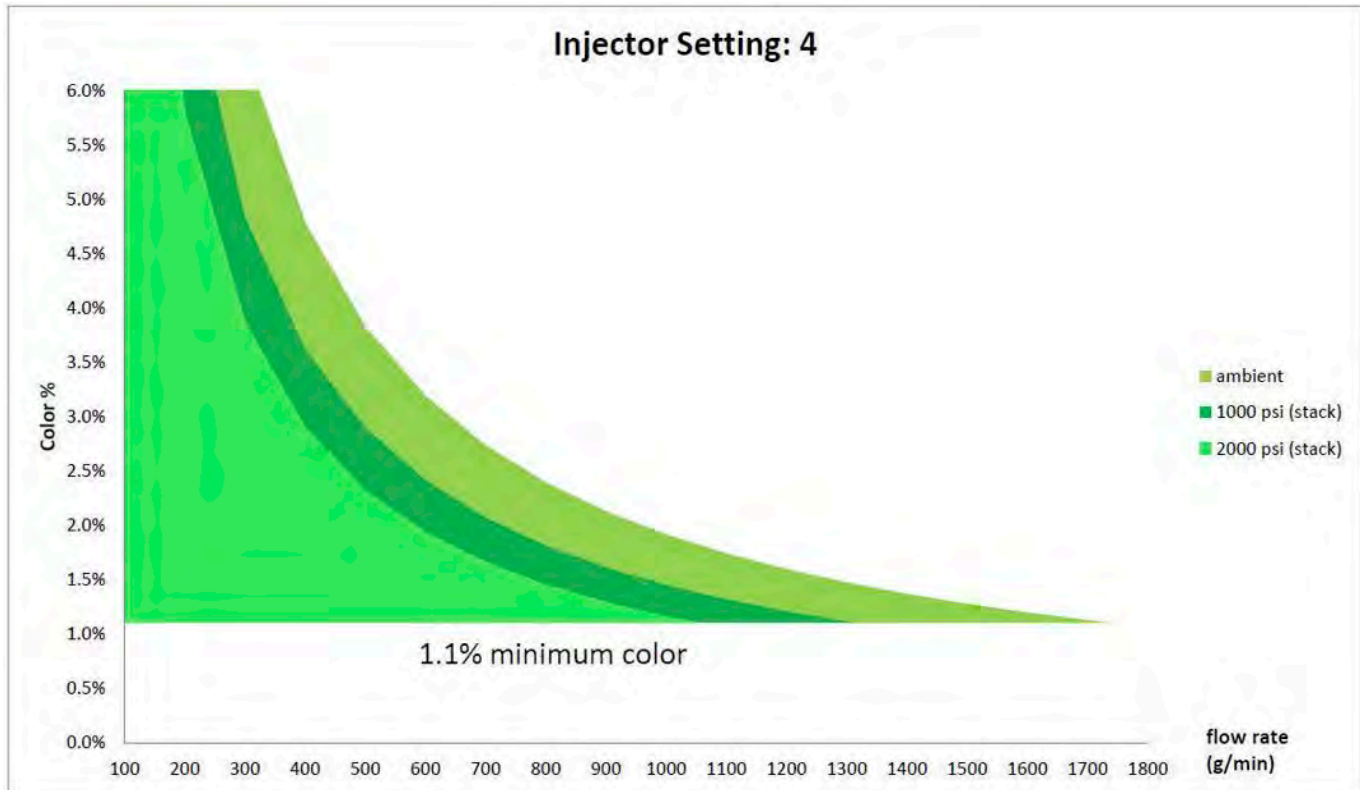
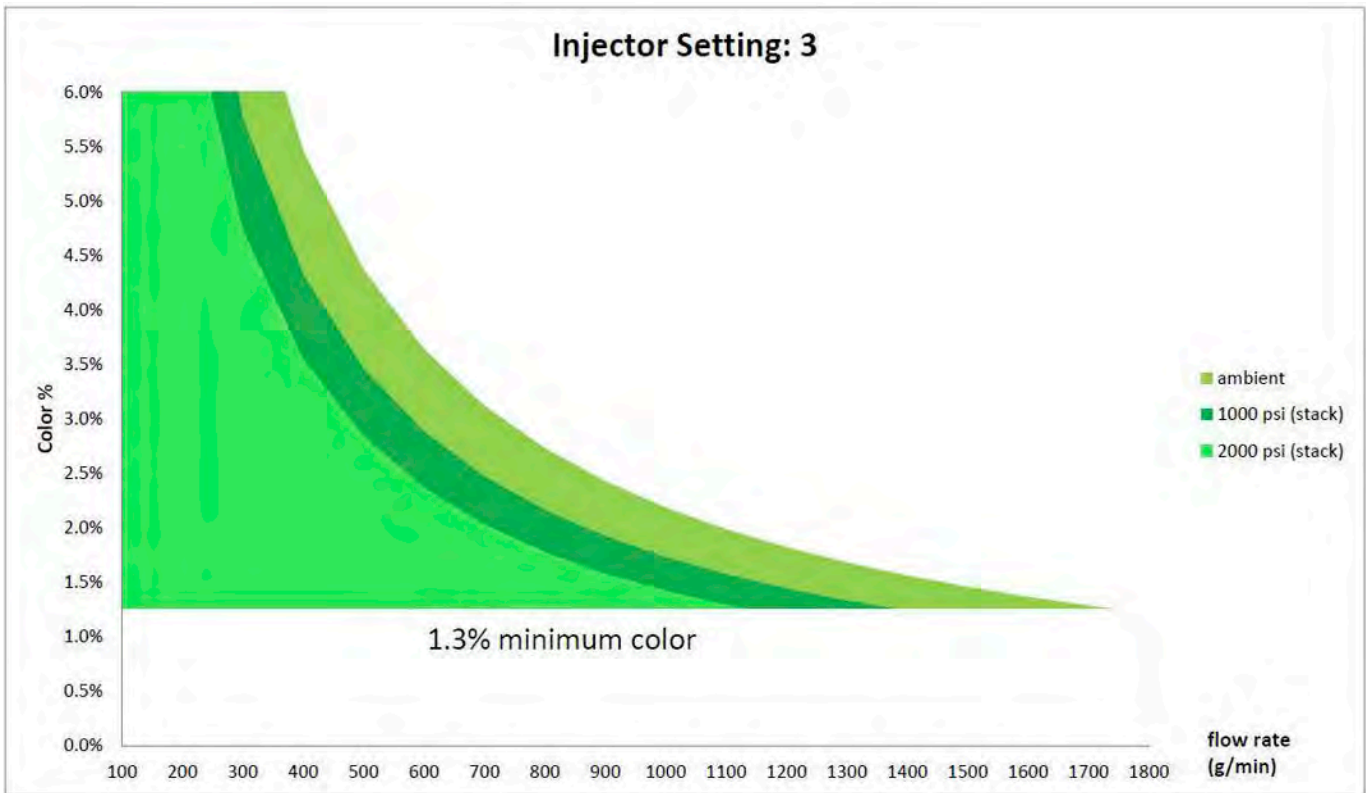

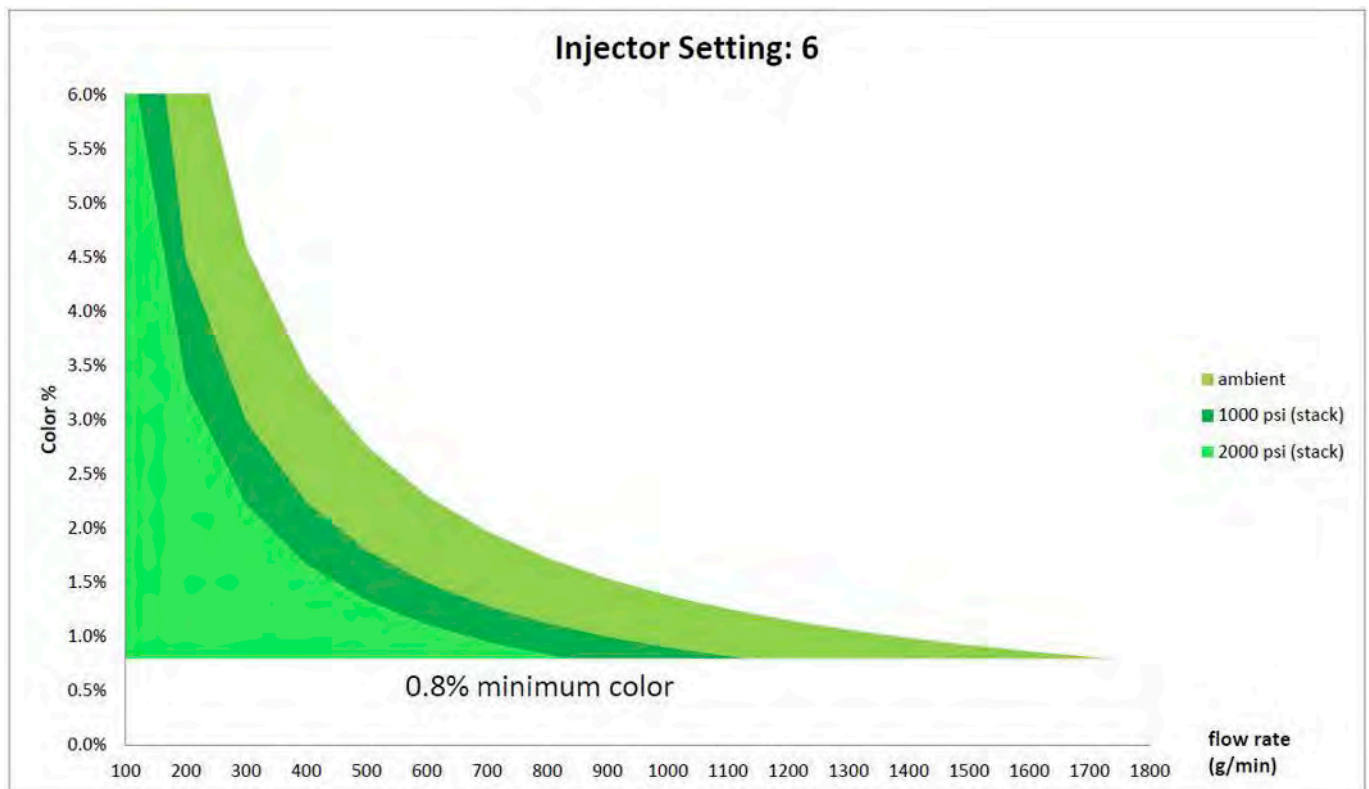
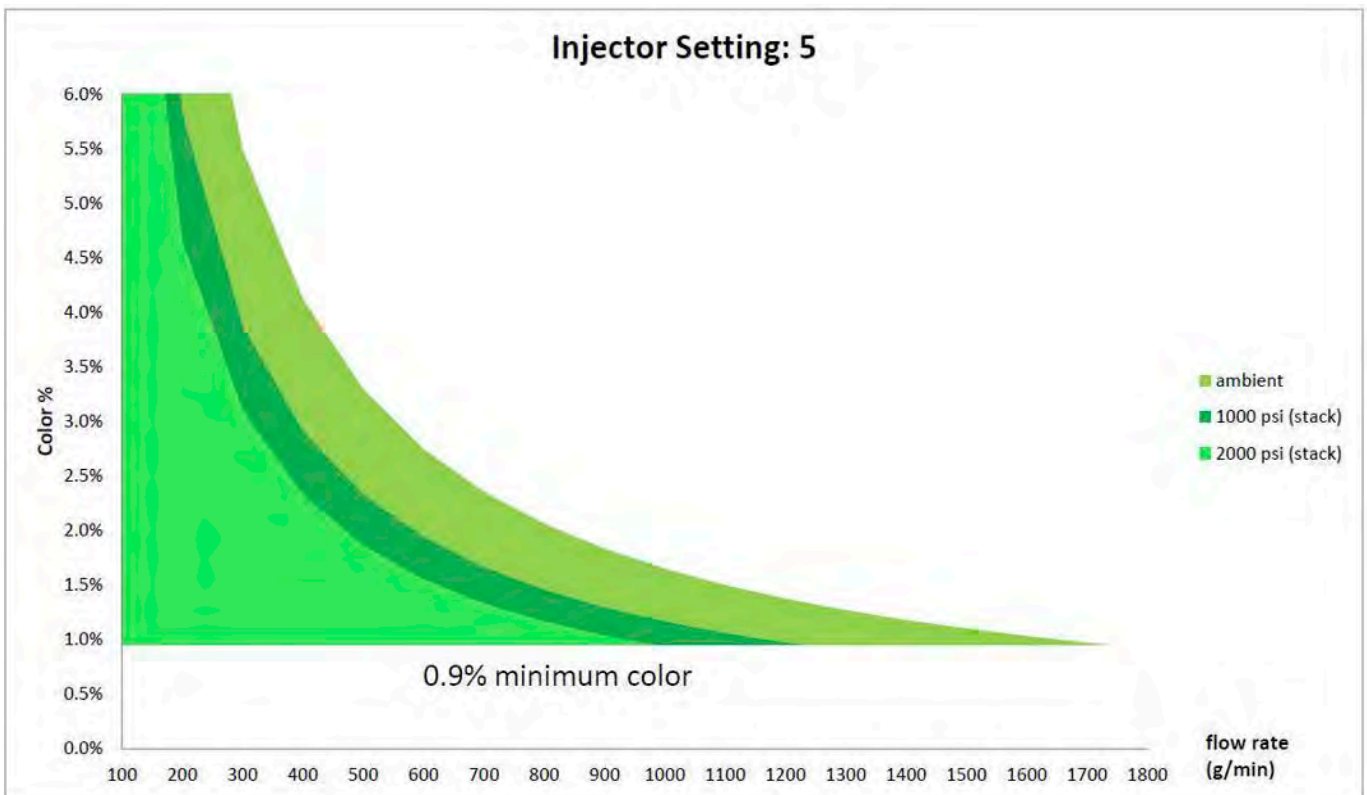

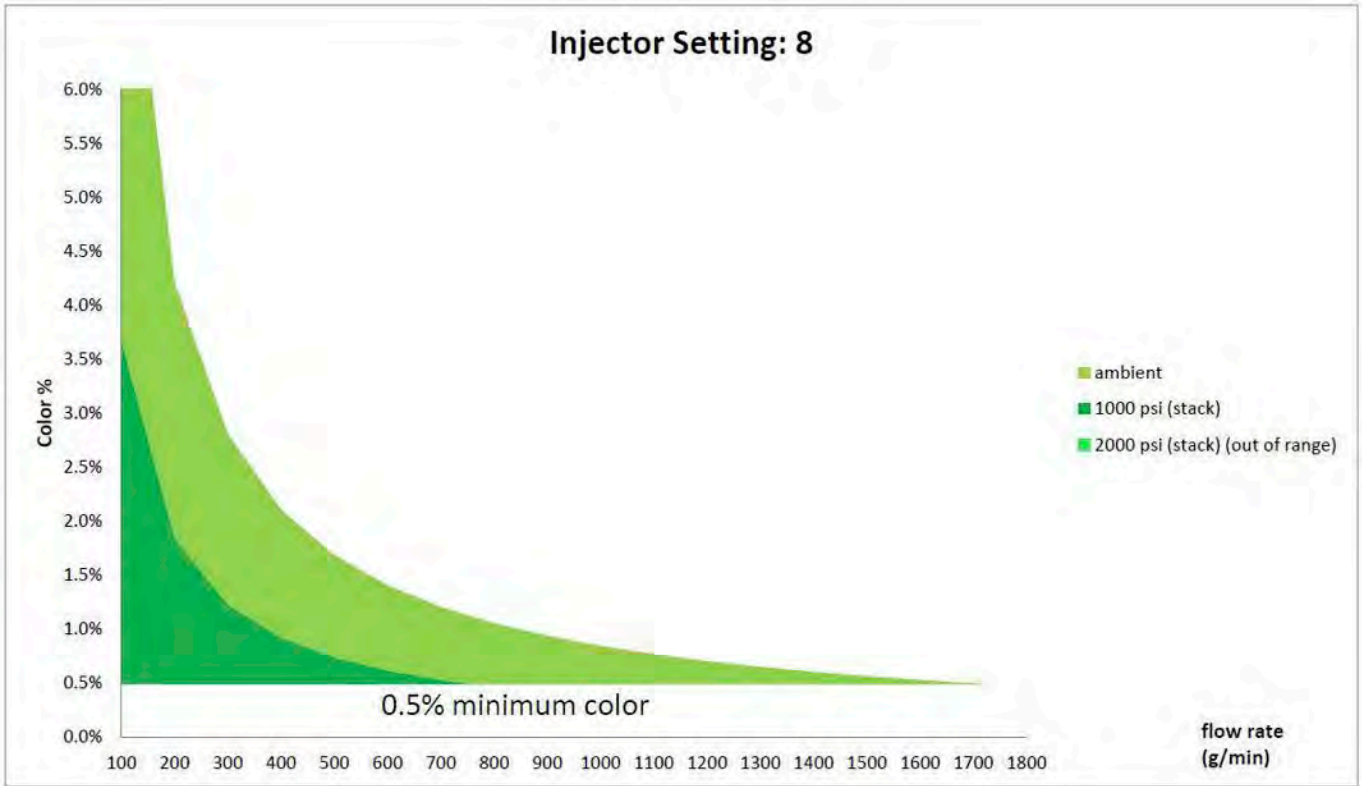
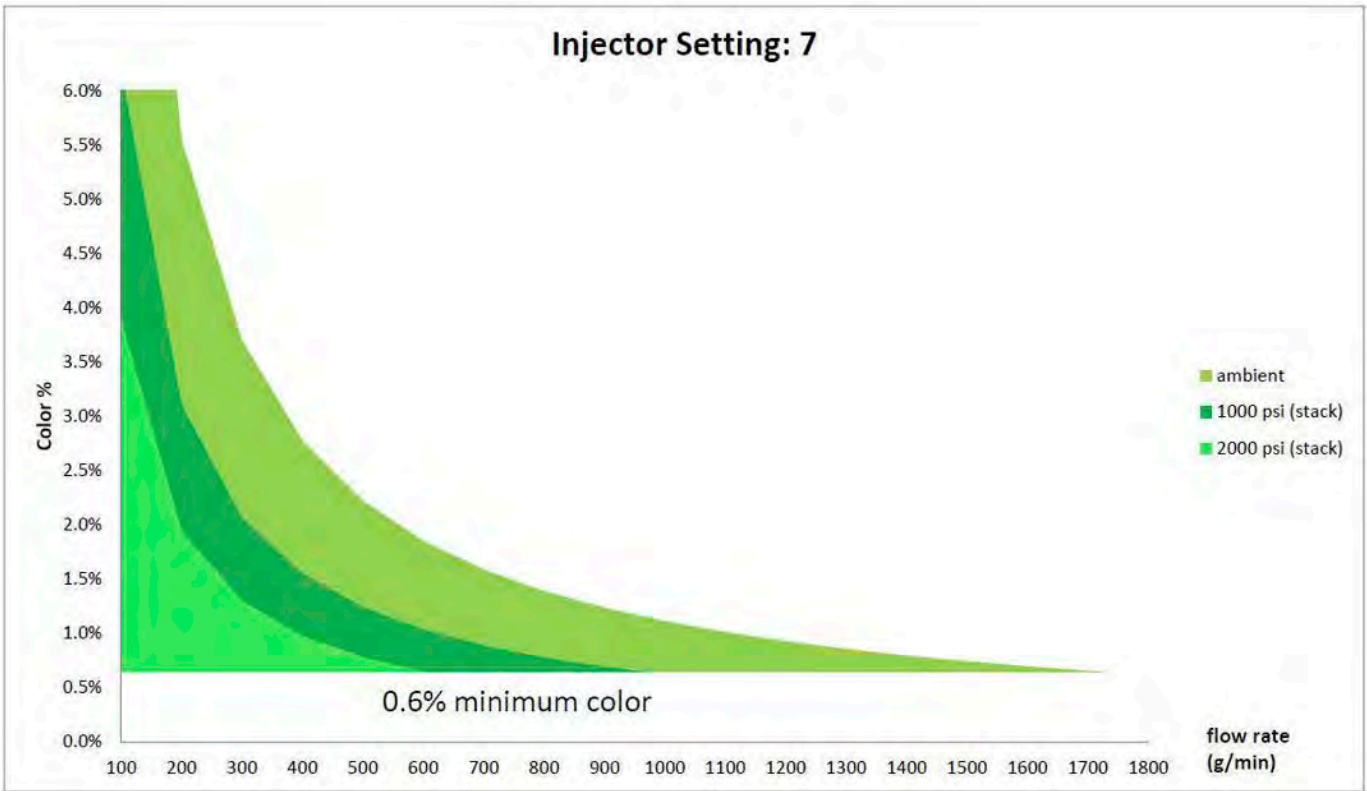

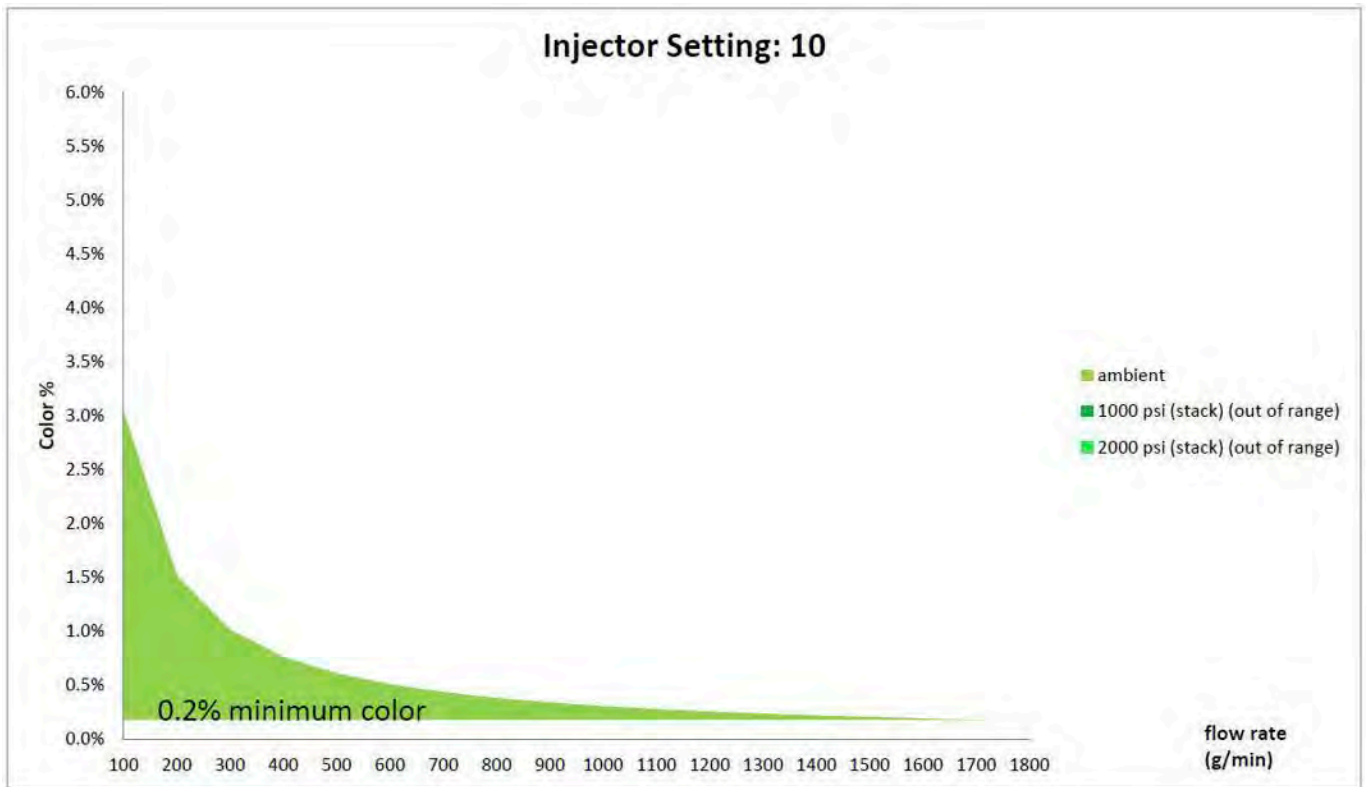
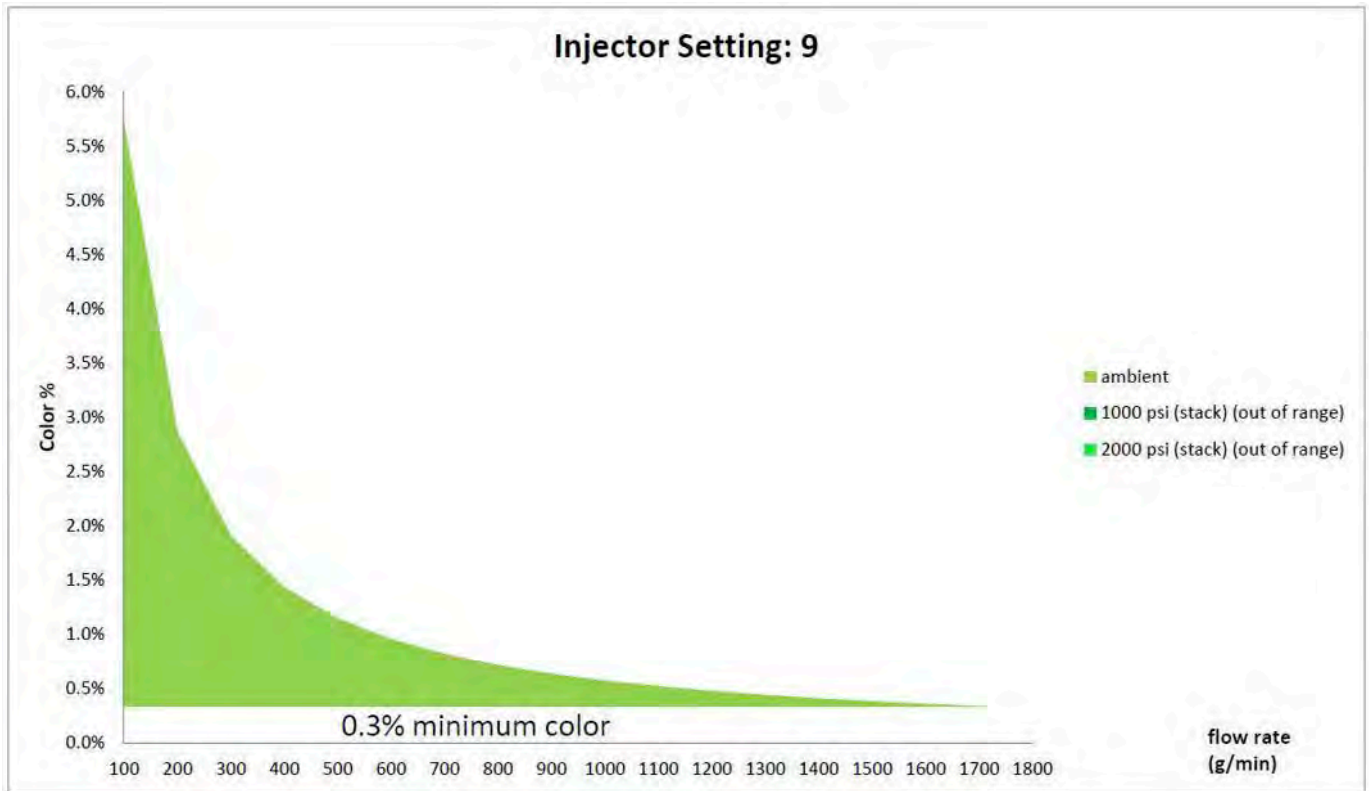

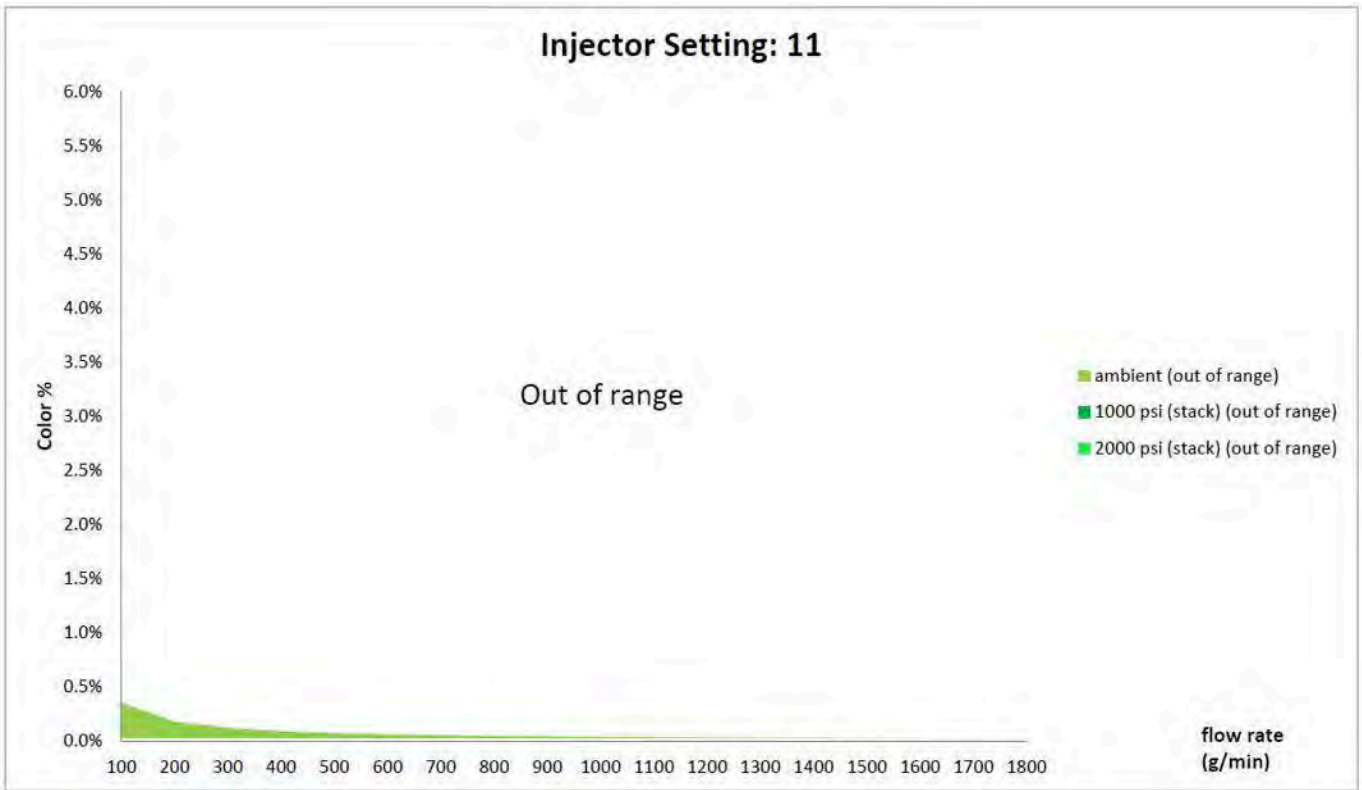

Schematics

FCM1 - Front

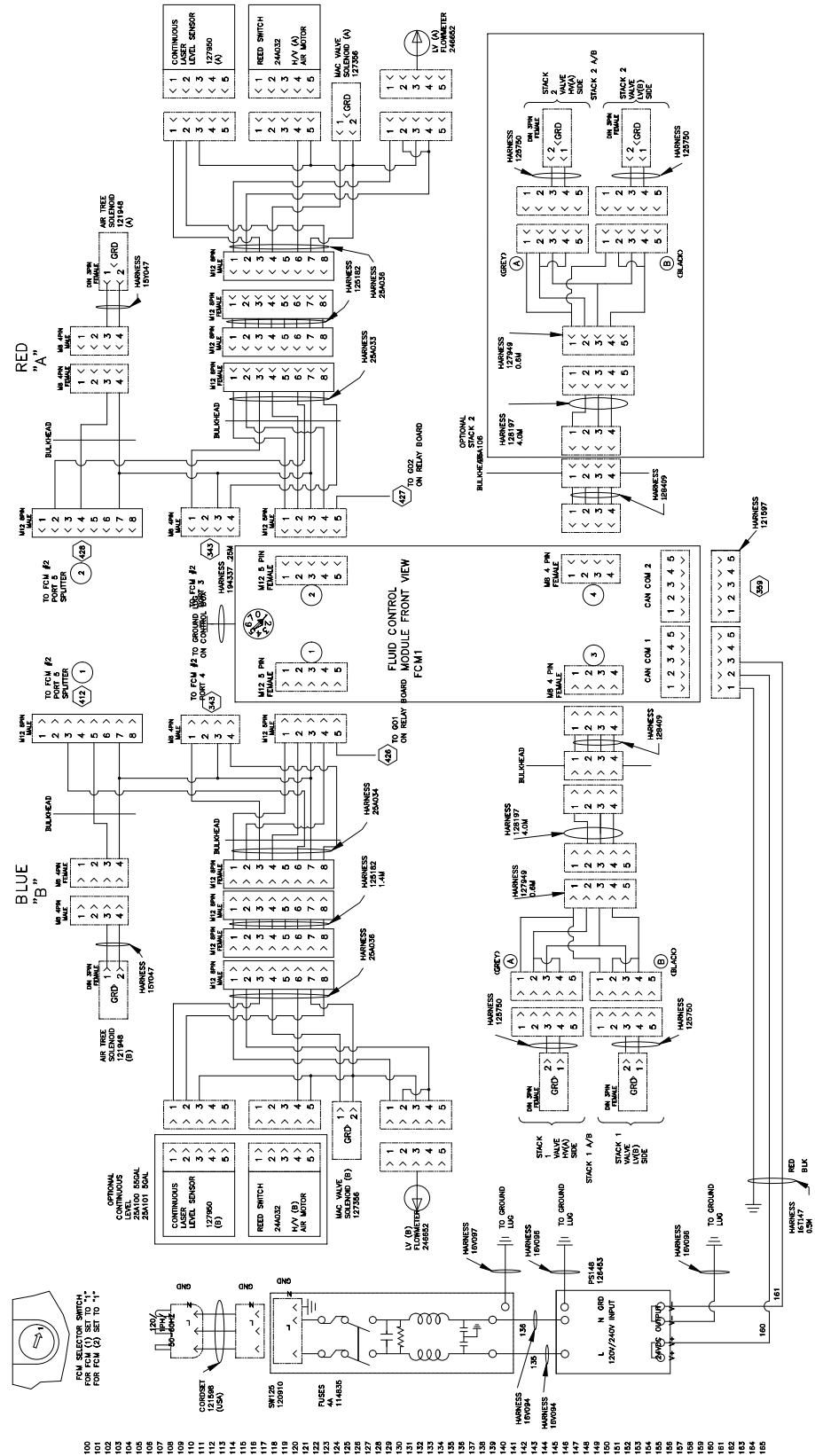

FCM1 - Back

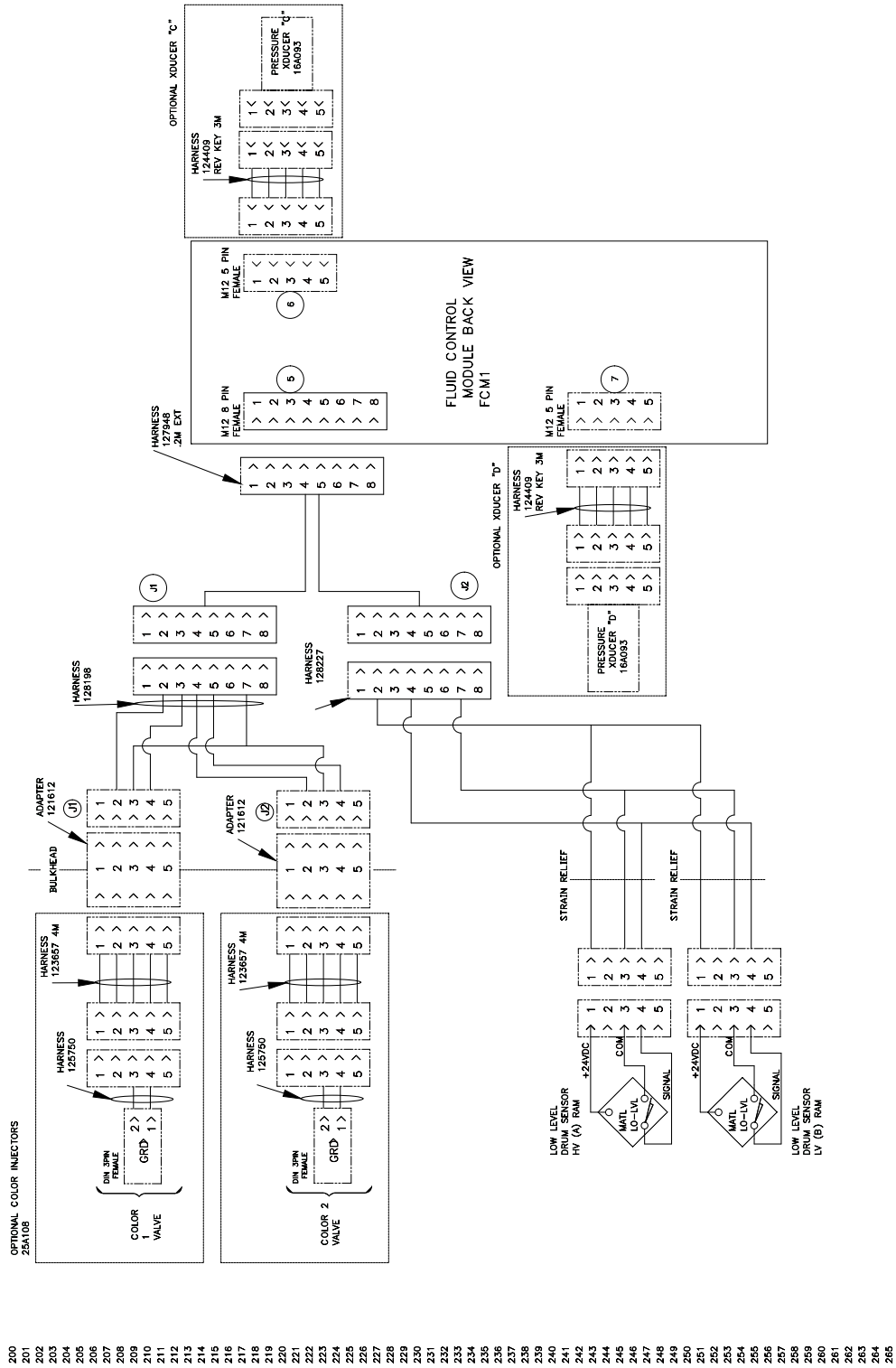

200
201
202
203
204
205
206
207
208
209
210
211
212
213
214
215
216
217
218
219
220
221
222
223
224
225
226
227
228
229
230
231
232
233
234
235
236
237
238
239
240
241
242
243
244
245
246
247
248
249
250
251
252
253
254
255
256
257
258
259
260
261
262
263
264
265

FCM2 - Front

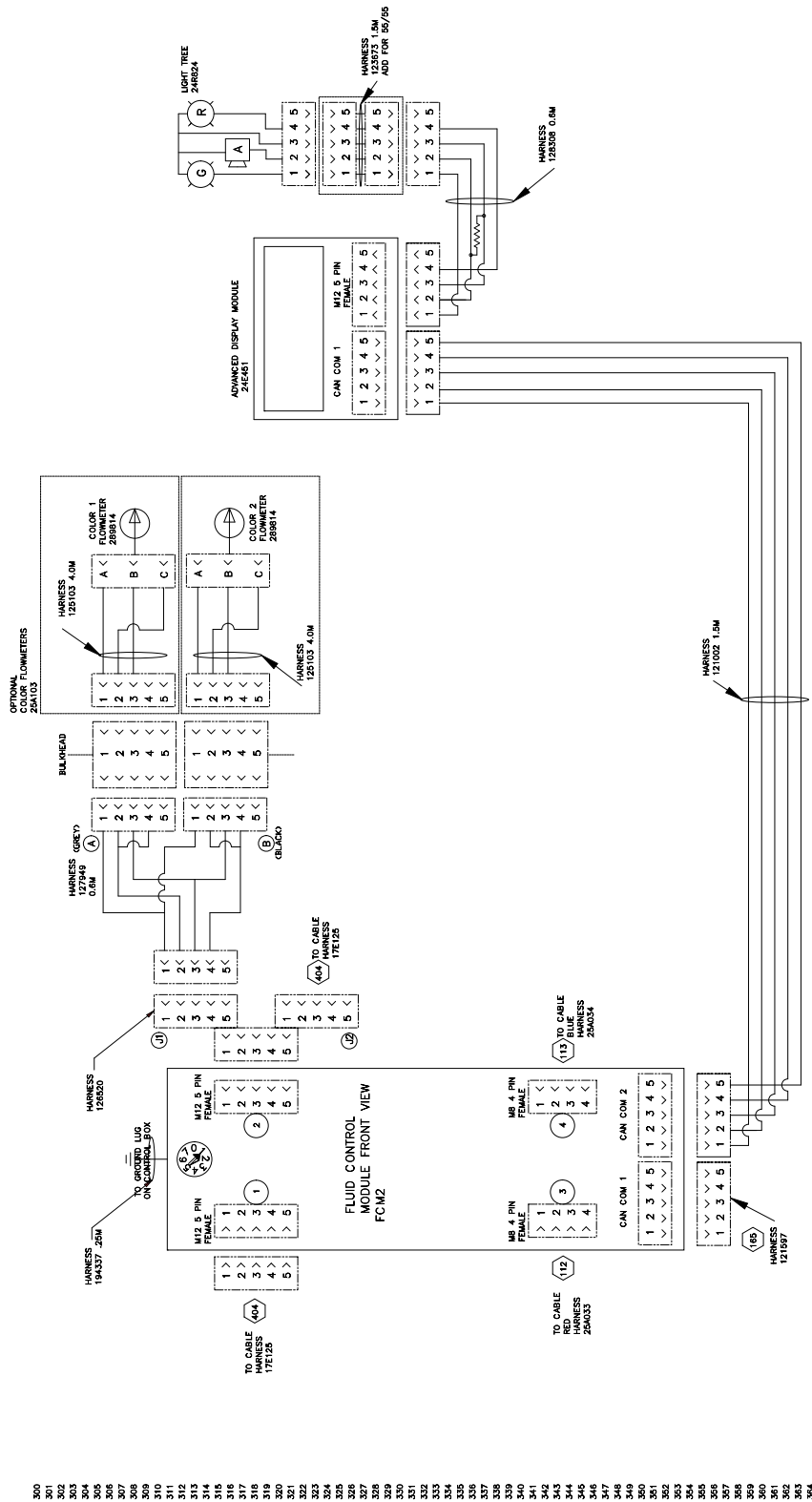

300
301
302
303
304
305
306
307
308
309
310
311
312
313
314
315
316
317
318
319
320
321
322
323
324
325
326
327
328
329
330
331
332
333
334
335
336
337
338
339
340
341
342
343
344
345
346
347
348
349
350
351
352
353
354
355
356
357
358
359
360
361
362
363
364
365

FCM2 - Back

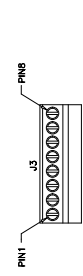
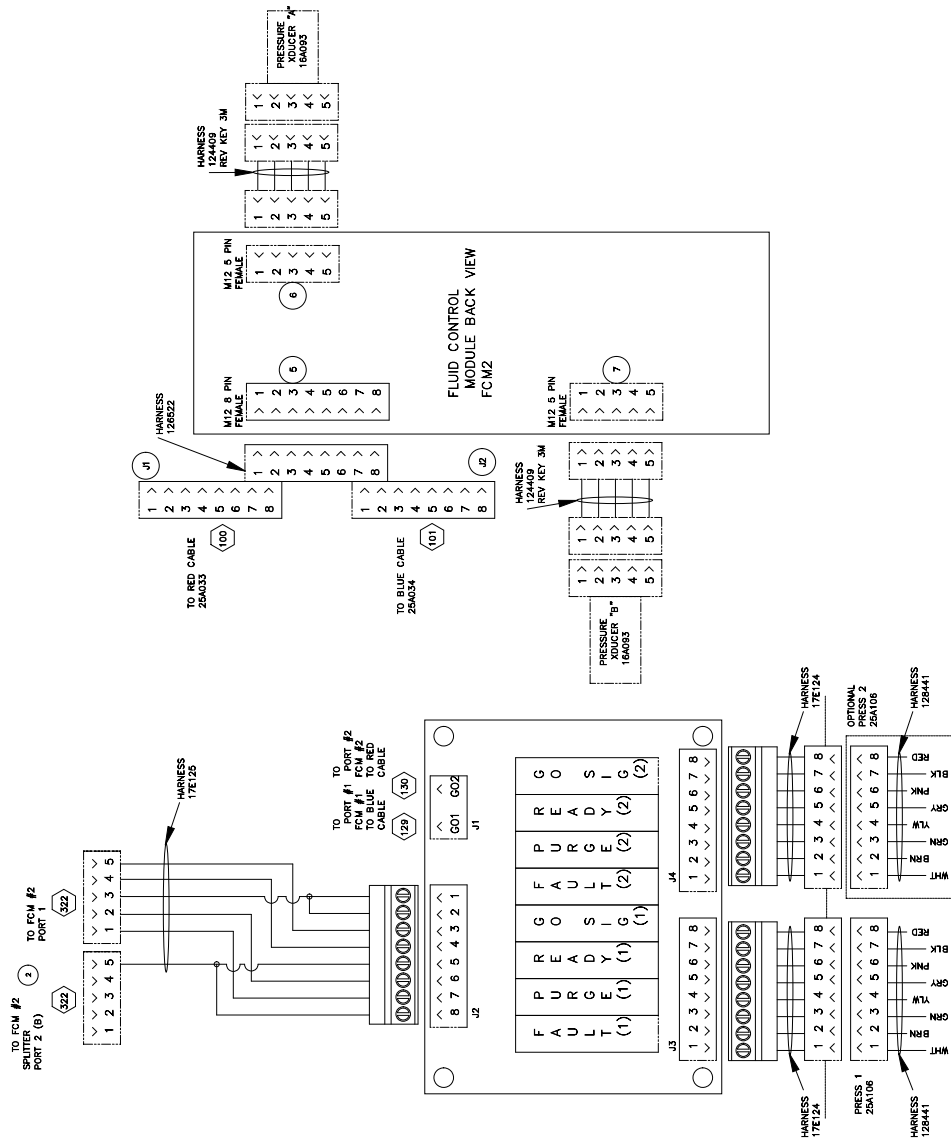

PN NUMBER	PN USAGE	COLOR	FUNCTION
1	24V+	WHT	GO Press (24V)
2	24V+	WHT	GO Press (24V)
3	COM	GRN	COMMON (12/7P)
4	COM	GRN	COMMON (12/7P)
5	FLY	YEL	FALL 1
6	FLY	YEL	FALL 2
7	FLY	YEL	FALL 3
8	FLY	YEL	FALL 4
9	FLY	YEL	FALL 5
10	FLY	YEL	FALL 6
11	FLY	YEL	FALL 7
12	FLY	YEL	FALL 8
13	FLY	YEL	FALL 9
14	FLY	YEL	FALL 10
15	FLY	YEL	FALL 11
16	FLY	YEL	FALL 12
17	FLY	YEL	FALL 13
18	FLY	YEL	FALL 14
19	FLY	YEL	FALL 15
20	FLY	YEL	FALL 16
21	FLY	YEL	FALL 17
22	FLY	YEL	FALL 18
23	FLY	YEL	FALL 19
24	FLY	YEL	FALL 20
25	FLY	YEL	FALL 21
26	FLY	YEL	FALL 22
27	FLY	YEL	FALL 23
28	FLY	YEL	FALL 24
29	FLY	YEL	FALL 25
30	FLY	YEL	FALL 26
31	FLY	YEL	FALL 27
32	FLY	YEL	FALL 28
33	FLY	YEL	FALL 29
34	FLY	YEL	FALL 30
35	FLY	YEL	FALL 31
36	FLY	YEL	FALL 32
37	FLY	YEL	FALL 33
38	FLY	YEL	FALL 34
39	FLY	YEL	FALL 35
40	FLY	YEL	FALL 36
41	FLY	YEL	FALL 37
42	FLY	YEL	FALL 38
43	FLY	YEL	FALL 39
44	FLY	YEL	FALL 40
45	FLY	YEL	FALL 41
46	FLY	YEL	FALL 42
47	FLY	YEL	FALL 43
48	FLY	YEL	FALL 44
49	FLY	YEL	FALL 45
50	FLY	YEL	FALL 46
51	FLY	YEL	FALL 47
52	FLY	YEL	FALL 48
53	FLY	YEL	FALL 49
54	FLY	YEL	FALL 50
55	FLY	YEL	FALL 51
56	FLY	YEL	FALL 52
57	FLY	YEL	FALL 53
58	FLY	YEL	FALL 54
59	FLY	YEL	FALL 55
60	FLY	YEL	FALL 56
61	FLY	YEL	FALL 57
62	FLY	YEL	FALL 58
63	FLY	YEL	FALL 59
64	FLY	YEL	FALL 60
65	FLY	YEL	FALL 61
66	FLY	YEL	FALL 62
67	FLY	YEL	FALL 63
68	FLY	YEL	FALL 64
69	FLY	YEL	FALL 65
70	FLY	YEL	FALL 66
71	FLY	YEL	FALL 67
72	FLY	YEL	FALL 68
73	FLY	YEL	FALL 69
74	FLY	YEL	FALL 70
75	FLY	YEL	FALL 71
76	FLY	YEL	FALL 72
77	FLY	YEL	FALL 73
78	FLY	YEL	FALL 74
79	FLY	YEL	FALL 75
80	FLY	YEL	FALL 76
81	FLY	YEL	FALL 77
82	FLY	YEL	FALL 78
83	FLY	YEL	FALL 79
84	FLY	YEL	FALL 80
85	FLY	YEL	FALL 81
86	FLY	YEL	FALL 82
87	FLY	YEL	FALL 83
88	FLY	YEL	FALL 84
89	FLY	YEL	FALL 85
90	FLY	YEL	FALL 86
91	FLY	YEL	FALL 87
92	FLY	YEL	FALL 88
93	FLY	YEL	FALL 89
94	FLY	YEL	FALL 90
95	FLY	YEL	FALL 91
96	FLY	YEL	FALL 92
97	FLY	YEL	FALL 93
98	FLY	YEL	FALL 94
99	FLY	YEL	FALL 95
100	FLY	YEL	FALL 96
101	FLY	YEL	FALL 97
102	FLY	YEL	FALL 98
103	FLY	YEL	FALL 99
104	FLY	YEL	FALL 100

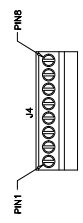

PN NUMBER	PN USAGE	COLOR	FUNCTION
1	24V+	WHT	GO Press (24V)
2	24V+	WHT	GO Press (24V)
3	COM	GRN	COMMON (12/7P)
4	COM	GRN	COMMON (12/7P)
5	FLY	YEL	FALL 1
6	FLY	YEL	FALL 2
7	FLY	YEL	FALL 3
8	FLY	YEL	FALL 4
9	FLY	YEL	FALL 5
10	FLY	YEL	FALL 6
11	FLY	YEL	FALL 7
12	FLY	YEL	FALL 8
13	FLY	YEL	FALL 9
14	FLY	YEL	FALL 10
15	FLY	YEL	FALL 11
16	FLY	YEL	FALL 12
17	FLY	YEL	FALL 13
18	FLY	YEL	FALL 14
19	FLY	YEL	FALL 15
20	FLY	YEL	FALL 16
21	FLY	YEL	FALL 17
22	FLY	YEL	FALL 18
23	FLY	YEL	FALL 19
24	FLY	YEL	FALL 20
25	FLY	YEL	FALL 21
26	FLY	YEL	FALL 22
27	FLY	YEL	FALL 23
28	FLY	YEL	FALL 24
29	FLY	YEL	FALL 25
30	FLY	YEL	FALL 26
31	FLY	YEL	FALL 27
32	FLY	YEL	FALL 28
33	FLY	YEL	FALL 29
34	FLY	YEL	FALL 30
35	FLY	YEL	FALL 31
36	FLY	YEL	FALL 32
37	FLY	YEL	FALL 33
38	FLY	YEL	FALL 34
39	FLY	YEL	FALL 35
40	FLY	YEL	FALL 36
41	FLY	YEL	FALL 37
42	FLY	YEL	FALL 38
43	FLY	YEL	FALL 39
44	FLY	YEL	FALL 40
45	FLY	YEL	FALL 41
46	FLY	YEL	FALL 42
47	FLY	YEL	FALL 43
48	FLY	YEL	FALL 44
49	FLY	YEL	FALL 45
50	FLY	YEL	FALL 46
51	FLY	YEL	FALL 47
52	FLY	YEL	FALL 48
53	FLY	YEL	FALL 49
54	FLY	YEL	FALL 50
55	FLY	YEL	FALL 51
56	FLY	YEL	FALL 52
57	FLY	YEL	FALL 53
58	FLY	YEL	FALL 54
59	FLY	YEL	FALL 55
60	FLY	YEL	FALL 56
61	FLY	YEL	FALL 57
62	FLY	YEL	FALL 58
63	FLY	YEL	FALL 59
64	FLY	YEL	FALL 60
65	FLY	YEL	FALL 61
66	FLY	YEL	FALL 62
67	FLY	YEL	FALL 63
68	FLY	YEL	FALL 64
69	FLY	YEL	FALL 65
70	FLY	YEL	FALL 66
71	FLY	YEL	FALL 67
72	FLY	YEL	FALL 68
73	FLY	YEL	FALL 69
74	FLY	YEL	FALL 70
75	FLY	YEL	FALL 71
76	FLY	YEL	FALL 72
77	FLY	YEL	FALL 73
78	FLY	YEL	FALL 74
79	FLY	YEL	FALL 75
80	FLY	YEL	FALL 76
81	FLY	YEL	FALL 77
82	FLY	YEL	FALL 78
83	FLY	YEL	FALL 79
84	FLY	YEL	FALL 80
85	FLY	YEL	FALL 81
86	FLY	YEL	FALL 82
87	FLY	YEL	FALL 83
88	FLY	YEL	FALL 84
89	FLY	YEL	FALL 85
90	FLY	YEL	FALL 86
91	FLY	YEL	FALL 87
92	FLY	YEL	FALL 88
93	FLY	YEL	FALL 89
94	FLY	YEL	FALL 90
95	FLY	YEL	FALL 91
96	FLY	YEL	FALL 92
97	FLY	YEL	FALL 93
98	FLY	YEL	FALL 94
99	FLY	YEL	FALL 95
100	FLY	YEL	FALL 96
101	FLY	YEL	FALL 97
102	FLY	YEL	FALL 98
103	FLY	YEL	FALL 99
104	FLY	YEL	FALL 100



PN NUMBER	PN USAGE	COLOR
1	GRD	BLU/BLU
2	GRD	BLU/BLU
3	GRD	BLU/BLU
4	GRD	BLU/BLU
5	GRD	BLU/BLU
6	GRD	BLU/BLU
7	GRD	BLU/BLU
8	GRD	BLU/BLU
9	GRD	BLU/BLU
10	GRD	BLU/BLU
11	GRD	BLU/BLU
12	GRD	BLU/BLU
13	GRD	BLU/BLU
14	GRD	BLU/BLU
15	GRD	BLU/BLU
16	GRD	BLU/BLU
17	GRD	BLU/BLU
18	GRD	BLU/BLU
19	GRD	BLU/BLU
20	GRD	BLU/BLU
21	GRD	BLU/BLU
22	GRD	BLU/BLU
23	GRD	BLU/BLU
24	GRD	BLU/BLU
25	GRD	BLU/BLU
26	GRD	BLU/BLU
27	GRD	BLU/BLU
28	GRD	BLU/BLU
29	GRD	BLU/BLU
30	GRD	BLU/BLU
31	GRD	BLU/BLU
32	GRD	BLU/BLU
33	GRD	BLU/BLU
34	GRD	BLU/BLU
35	GRD	BLU/BLU
36	GRD	BLU/BLU
37	GRD	BLU/BLU
38	GRD	BLU/BLU
39	GRD	BLU/BLU
40	GRD	BLU/BLU
41	GRD	BLU/BLU
42	GRD	BLU/BLU
43	GRD	BLU/BLU
44	GRD	BLU/BLU
45	GRD	BLU/BLU
46	GRD	BLU/BLU
47	GRD	BLU/BLU
48	GRD	BLU/BLU
49	GRD	BLU/BLU
50	GRD	BLU/BLU
51	GRD	BLU/BLU
52	GRD	BLU/BLU
53	GRD	BLU/BLU
54	GRD	BLU/BLU
55	GRD	BLU/BLU
56	GRD	BLU/BLU
57	GRD	BLU/BLU
58	GRD	BLU/BLU
59	GRD	BLU/BLU
60	GRD	BLU/BLU
61	GRD	BLU/BLU
62	GRD	BLU/BLU
63	GRD	BLU/BLU
64	GRD	BLU/BLU
65	GRD	BLU/BLU
66	GRD	BLU/BLU
67	GRD	BLU/BLU
68	GRD	BLU/BLU
69	GRD	BLU/BLU
70	GRD	BLU/BLU
71	GRD	BLU/BLU
72	GRD	BLU/BLU
73	GRD	BLU/BLU
74	GRD	BLU/BLU
75	GRD	BLU/BLU
76	GRD	BLU/BLU
77	GRD	BLU/BLU
78	GRD	BLU/BLU
79	GRD	BLU/BLU
80	GRD	BLU/BLU
81	GRD	BLU/BLU
82	GRD	BLU/BLU
83	GRD	BLU/BLU
84	GRD	BLU/BLU
85	GRD	BLU/BLU
86	GRD	BLU/BLU
87	GRD	BLU/BLU
88	GRD	BLU/BLU
89	GRD	BLU/BLU
90	GRD	BLU/BLU
91	GRD	BLU/BLU
92	GRD	BLU/BLU
93	GRD	BLU/BLU
94	GRD	BLU/BLU
95	GRD	BLU/BLU
96	GRD	BLU/BLU
97	GRD	BLU/BLU
98	GRD	BLU/BLU
99	GRD	BLU/BLU
100	GRD	BLU/BLU

400
401
402
403
404
405
406
407
408
409
410
411
412
413
414
415
416
417
418
419
420
421
422
423
424
425
426
427
428
429
430
431
432
433
434
435
436
437
438
439
440
441
442
443
444
445
446
447
448
449
450
451
452
453
454
455
456
457
458
459
460
461
462
463
464
465

Dimensions

Model F4-5

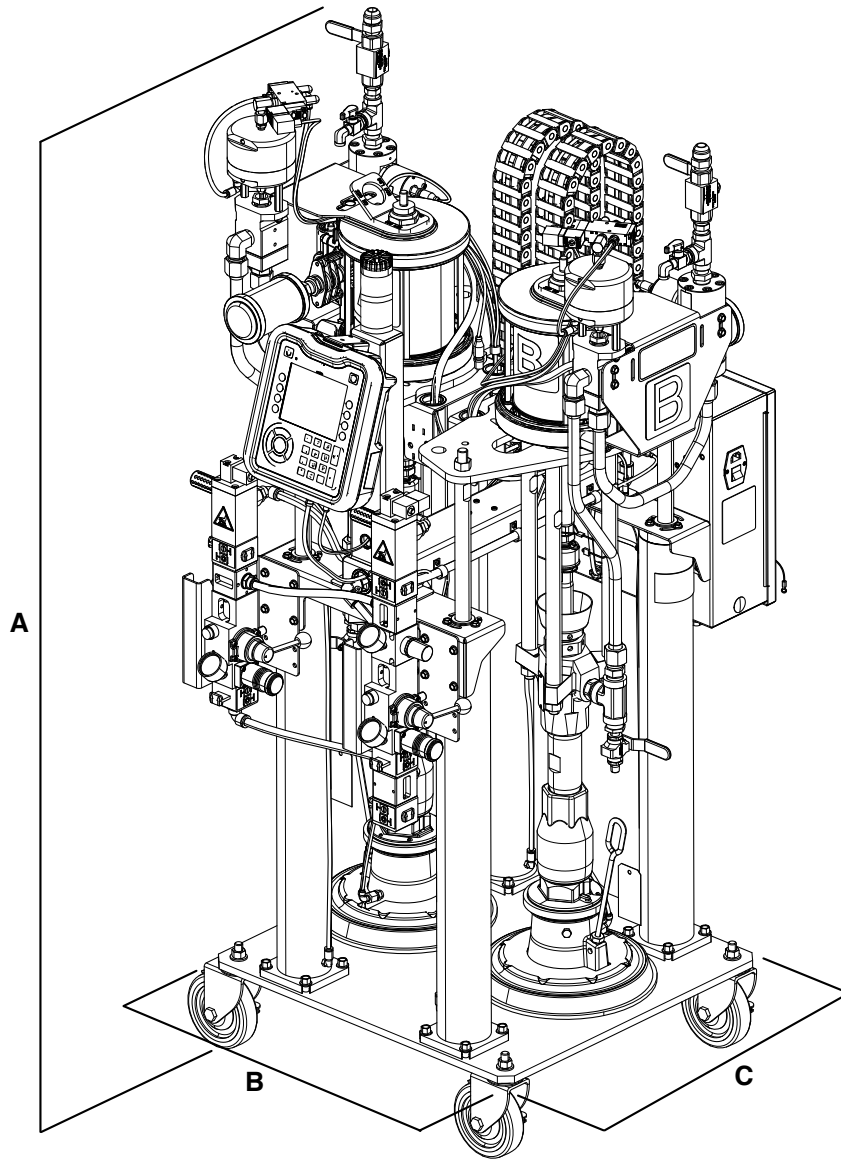

Dimensions	US (ft.)	Metric (m)
A (Height)	5.5	1.67
(Height Extended)	7.25	2.21
B (Base Width)	2.1	.64
C (Base Length)	1.9	.58
D (Machine Width)	2.9	.88
E (Machine Length)	2.95	.90

Dimensions

Top View

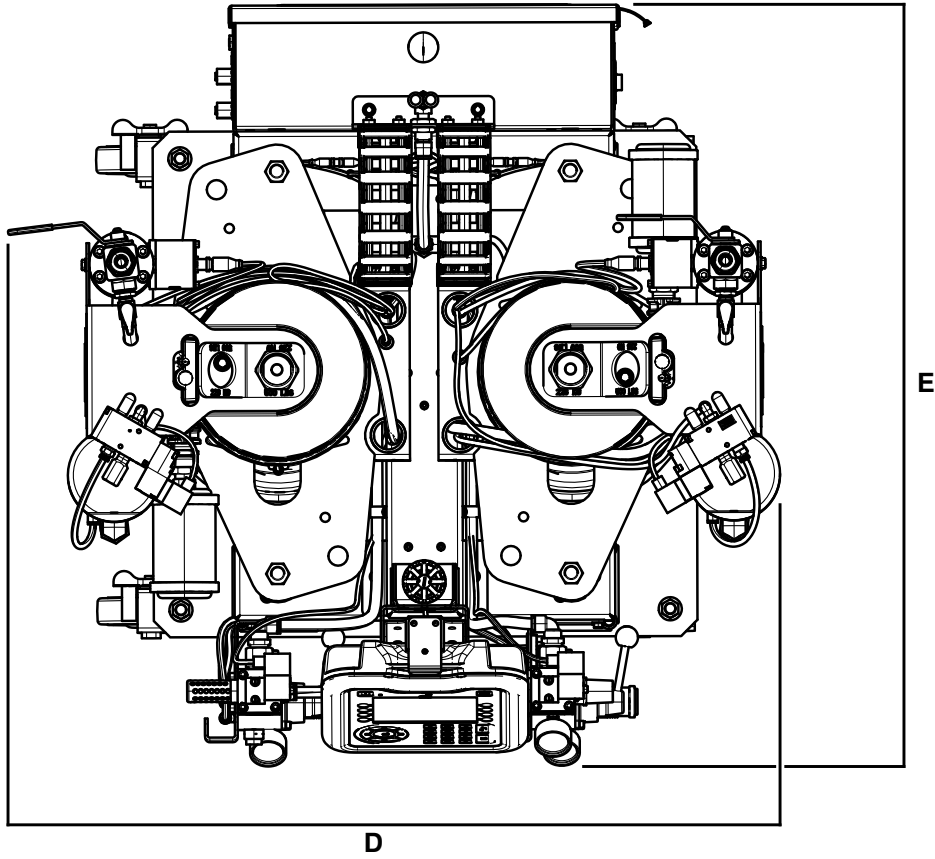

Model F4-55 and F4-55-5

F4-55 Shown

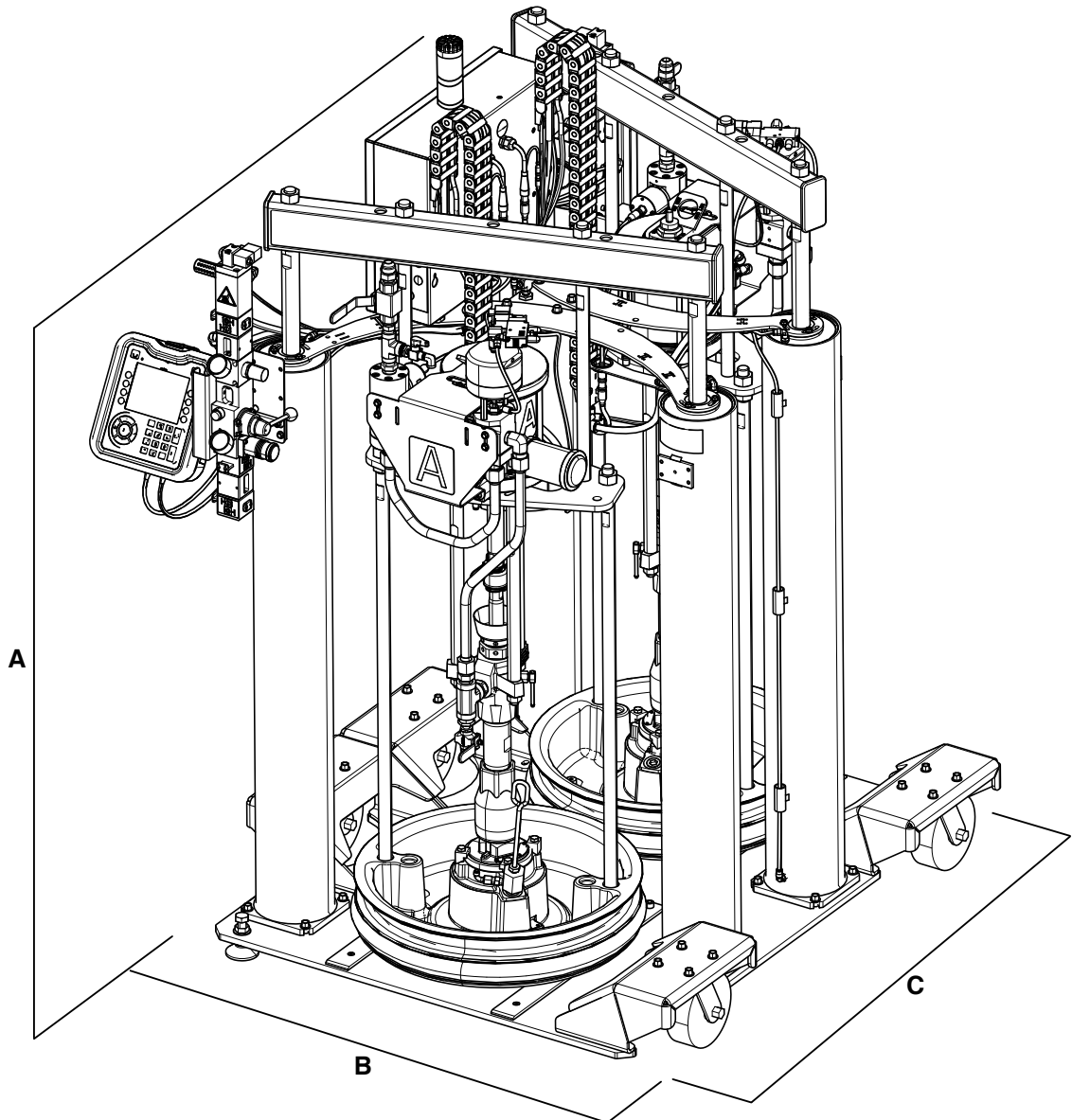

Dimensions	US (ft.)	Metric (m)
A (Height)	5.75	1.74
(Height Extended)	10.0	3.05
B (Base Width)	3.8 (with casters) 3.2 (without casters)	1.15 .98
C (Base Length)	3.9	1.18
D (Machine Width)	4.3	1.31
E (Machine Length)	4.5	1.37

Top View

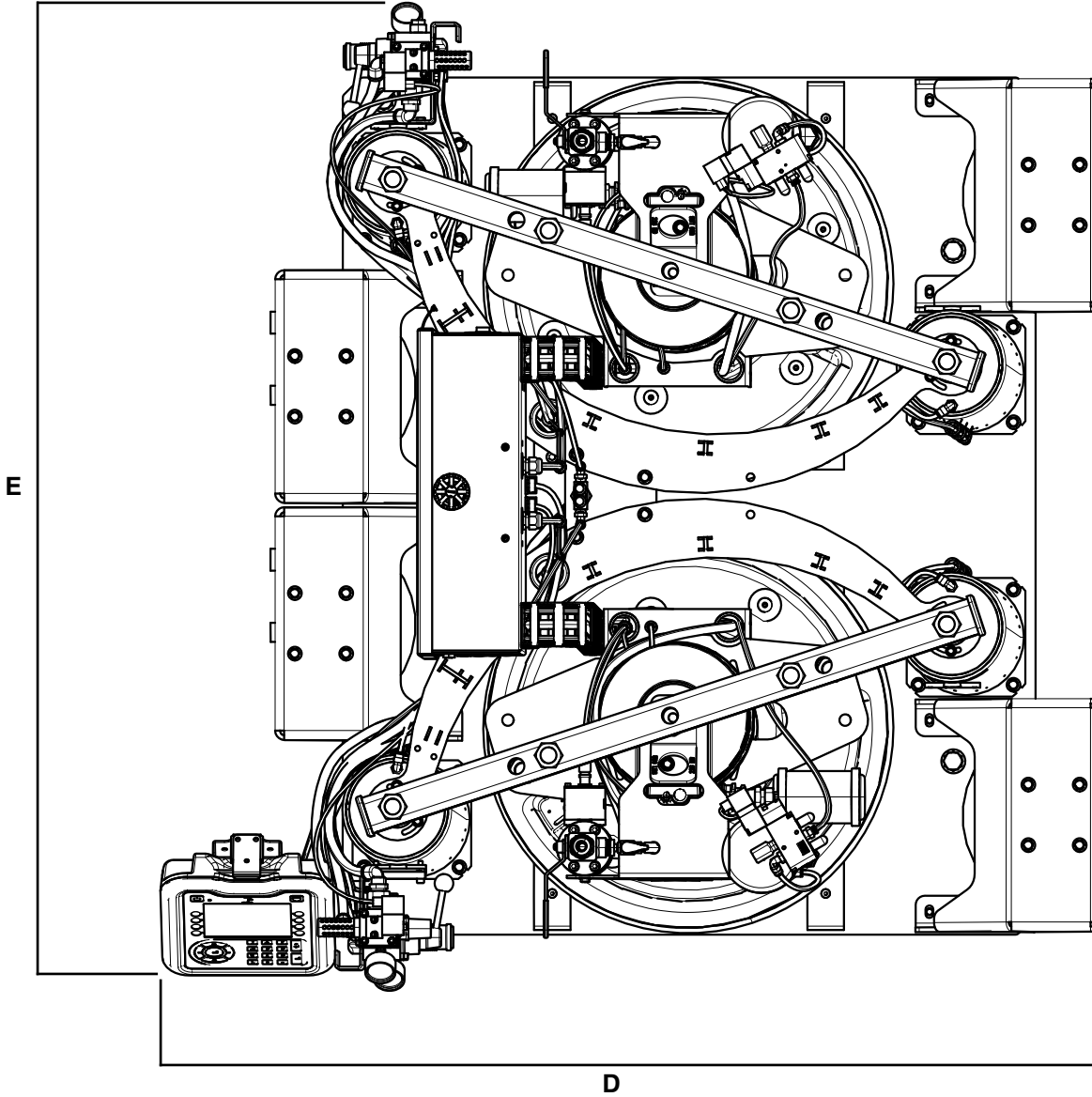

Technical Data

Fluid Automation F4 Series		
	US	Metric
Maximum output pressure	3000 psi	241 bar, 24.1 MPa
Air pressure requirements	80-100 psi	5.5-7.0 bar, 0.55-0.7 MPa
Maximum operating temperature	120° F	50° C
Power requirements	95-264 VAC, 50/60 Hz, 4A single phase	
Viscosity range	50,000 to 5,000,000 cps	
Flow rate	Minimum: 10 g/min; Maximum: 5 lb/min at 500,000 cps	
Ratio	1:1	
Pigment ratio range color injector style	0.5% to 6%	
Sound pressure level (LAeq)*	70.4 dB(A)	
Wetted parts**	Cast aluminum, FDA approved white neoprene, chrome, stainless steel, tungsten carbide, PTFE, PTFE-coated nitrile, UHMW polyethylene, Buna-N, fluoroelastomer, acetal	
Inlet/Outlet Sizes		
Air inlet size	1/2 in. npt (f)	
Fluid outlet base	1/2 in. npt (f)	
Fluid outlet catalyst	1/2 in. npt (f)	
Weight		
F4-5	564 lb	256 kg
F4-55 with casters	1,290 lb	585 kg
F4-55 without casters	1,200 lb	544 kg
F4-55-5 with casters	1,240 lb	563 kg
F4-55-5 without casters	1,150 lb	522 kg
Notes		
* Sound pressure measured 3.3 feet (1 meter) from the ADM at 85 psi per ISO 11202.		
** Refer to specific component manual for more details.		

California Proposition 65

CALIFORNIA RESIDENTS

 **WARNING:** Cancer and reproductive harm – www.P65warnings.ca.gov.

Graco Standard Warranty

Graco warrants all equipment referenced in this document which is manufactured by Graco and bearing its name to be free from defects in material and workmanship on the date of sale to the original purchaser for use. With the exception of any special, extended, or limited warranty published by Graco, Graco will, for a period of twelve months from the date of sale, repair or replace any part of the equipment determined by Graco to be defective. This warranty applies only when the equipment is installed, operated and maintained in accordance with Graco's written recommendations.

This warranty does not cover, and Graco shall not be liable for general wear and tear, or any malfunction, damage or wear caused by faulty installation, misapplication, abrasion, corrosion, inadequate or improper maintenance, negligence, accident, tampering, or substitution of non-Graco component parts. Nor shall Graco be liable for malfunction, damage or wear caused by the incompatibility of Graco equipment with structures, accessories, equipment or materials not supplied by Graco, or the improper design, manufacture, installation, operation or maintenance of structures, accessories, equipment or materials not supplied by Graco.

This warranty is conditioned upon the prepaid return of the equipment claimed to be defective to an authorized Graco distributor for verification of the claimed defect. If the claimed defect is verified, Graco will repair or replace free of charge any defective parts. The equipment will be returned to the original purchaser transportation prepaid. If inspection of the equipment does not disclose any defect in material or workmanship, repairs will be made at a reasonable charge, which charges may include the costs of parts, labor, and transportation.

THIS WARRANTY IS EXCLUSIVE, AND IS IN LIEU OF ANY OTHER WARRANTIES, EXPRESS OR IMPLIED, INCLUDING BUT NOT LIMITED TO WARRANTY OF MERCHANTABILITY OR WARRANTY OF FITNESS FOR A PARTICULAR PURPOSE.

Graco's sole obligation and buyer's sole remedy for any breach of warranty shall be as set forth above. The buyer agrees that no other remedy (including, but not limited to, incidental or consequential damages for lost profits, lost sales, injury to person or property, or any other incidental or consequential loss) shall be available. Any action for breach of warranty must be brought within two (2) years of the date of sale.

GRACO MAKES NO WARRANTY, AND DISCLAIMS ALL IMPLIED WARRANTIES OF MERCHANTABILITY AND FITNESS FOR A PARTICULAR PURPOSE, IN CONNECTION WITH ACCESSORIES, EQUIPMENT, MATERIALS OR COMPONENTS SOLD BUT NOT MANUFACTURED BY GRACO. These items sold, but not manufactured by Graco (such as electric motors, switches, hose, etc.), are subject to the warranty, if any, of their manufacturer. Graco will provide purchaser with reasonable assistance in making any claim for breach of these warranties.

In no event will Graco be liable for indirect, incidental, special or consequential damages resulting from Graco supplying equipment hereunder, or the furnishing, performance, or use of any products or other goods sold hereto, whether due to a breach of contract, breach of warranty, the negligence of Graco, or otherwise.

FOR GRACO CANADA CUSTOMERS

The Parties acknowledge that they have required that the present document, as well as all documents, notices and legal proceedings entered into, given or instituted pursuant hereto or relating directly or indirectly hereto, be drawn up in English. Les parties reconnaissent avoir convenu que la rédaction du présente document sera en Anglais, ainsi que tous documents, avis et procédures judiciaires exécutés, donnés ou intentés, à la suite de ou en rapport, directement ou indirectement, avec les procédures concernées.

Graco Information

Sealant and Adhesive Dispensing Equipment

For the latest information about Graco products, visit www.graco.com.

For patent information, see www.graco.com/patents.

TO PLACE AN ORDER, contact your Graco distributor, go to www.graco.com and select "Where to Buy" in the top blue bar, or call to find the nearest distributor.

If calling from the US: 800-746-1334

If calling from outside the US: 0-1-330-966-3000

All written and visual data contained in this document reflects the latest product information available at the time of publication. Graco reserves the right to make changes at any time without notice.

Original instructions. This manual contains English. MM 335028

Graco Headquarters: Minneapolis

International Offices: Belgium, China, Japan, Korea

GRACO INC. AND SUBSIDIARIES • P.O. BOX 1441 • MINNEAPOLIS MN 55440-1441 • USA

Copyright 2015, Graco Inc. All Graco manufacturing locations are registered to ISO 9001.

www.graco.com

Revision H, September 2022